



Infrastructure Design Standard

Infrastructure Design Standard

Infrastructure Design Standard

TABLE OF CONTENTS

1	INTRODUCTION	10
1.1	General	10
1.2	Innovation and changing technologies	10
1.3	Definitions	11
1.4	Design requirements	16
1.5	Objectives	16
1.6	General	16
1.7	Pre-design site inspection	16
1.8	Variation from design specifications	17
2	DOCUMENTATION.....	18
2.1	Objectives	18
2.2	Plans	18
2.2.1	Sheet Size	18
2.2.2	Scales	18
2.2.3	Datum.....	18
2.2.4	Standard details	19
2.2.5	Drawing numbers	19
2.3	Standard drawings	19
2.4	Specifications	19
2.5	Information to be shown on plans	20
3	DESIGN OF ROADS.....	21
3.1	Objectives	21
3.2	General	21
3.3	Urban roads.....	21
3.3.1	Road classification	21
3.3.2	Road/street characteristics and road reserve widths.....	22

Infrastructure Design Standard

3.3.3	Widths and treatments of other reserves.....	25
3.3.4	Road geometry.....	25
3.3.5	Sight distances.....	25
3.3.6	Vertical alignment and vertical curve requirements.....	26
Table 3 – Sight stopping distance target speeds		26
3.3.7	Limiting longitudinal gradients.....	26
Table 4 – Limiting longitudinal grades		26
3.3.8	Vehicle turning movements.....	27
3.3.9	Cross section profiles.....	27
3.3.10	Kerb and gutter.....	28
3.4	Rural roads.....	29
3.4.1	General.....	29
3.4.2	Road reserves.....	29
3.4.3	Road geometry, horizontal and vertical alignments.....	30
Table 6 – Typical rural road desired speeds		30
3.4.4	Sight distances.....	30
3.4.5	Vertical curve requirements.....	31
3.4.6	Limiting longitudinal gradients.....	31
3.4.7	Cross section profiles.....	31
3.4.8	Vehicle turning movements.....	31
3.4.9	Kerb and gutter cut embankments.....	32
3.5	Intersection design.....	32
3.5.1	General.....	32
3.5.2	Level of treatment.....	32
3.5.3	Special considerations.....	33
3.5.4	Intersection spacing.....	33
3.5.5	Splays.....	33
3.5.6	Kerb returns.....	33
3.6	Traffic calming.....	33
3.7	Pavement design.....	35
3.7.1	Sub-grade analyses.....	35
3.7.2	Flexible road pavements.....	35
3.7.3	Concrete street pavements.....	36
3.7.4	Minimum pavement thickness.....	36

Infrastructure Design Standard

3.7.5	Minimum shoulder thickness	36
3.7.6	Pavement sub-base	36
3.7.7	Pavement wearing course.....	36
3.7.8	Connections to existing pavement.....	37
3.8	Traffic control devices	37
3.8.1	Signposting and pavement marking	37
3.8.2	Road safety barriers	37
3.9	Vehicular access.....	37
3.9.1	Rural vehicle crossings	38
3.10	Requirements for dust suppression	39
4	MOBILITY AND ACCESS PROVISIONS.....	40
4.1	Objectives	40
4.2	General	40
4.3	Requirements.....	40
5	CAR PARKING	41
5.1	Objectives	41
5.2	General	41
5.3	Requirements.....	41
6	EARTHWORKS AND LOT FILLING.....	43
6.1	Objectives	43
6.2	General	43
6.3	Requirements.....	43
6.3.1	Sediment and erosion control plans	44
7	URBAN DRAINAGE	45
7.1	Objectives	45
7.2	General	45
7.3	Floor levels.....	45
7.4	Hydrology.....	46

Infrastructure Design Standard

7.4.1	General	46
7.4.2	Catchment area.....	46
Table 7 – Land use impervious percentages		47
7.4.3	Time of concentration.....	47
7.4.4	Average Recurrence Interval (ARI) design parameters.....	47
Table 8 – Minor drainage system design		47
7.4.5	Rainfall Intensity Frequency Duration (IFD)	48
7.4.6	Coefficients of run-off	48
Table 9 – Frequency factors (FF_y)		48
7.5	Hydraulic design.....	48
7.5.1	General	48
Table 10 - Pipe roughness values		49
7.5.2	Downstream water surface level	49
7.5.3	Pipes	49
7.5.3.1	Size.....	49
7.5.3.2	Velocity	49
7.5.3.3	Grade.....	50
7.5.3.4	Pipe cover/depth.....	50
7.5.3.5	Pit losses	51
7.5.4	Gutter flow width.....	51
7.6	Pipes	51
7.6.1	Pipe class.....	51
7.6.2	Pipe alignment at pits	51
7.6.3	Maximum length	52
7.6.4	Pipe bedding and connection	52
7.6.5	Curved pipelines.....	52
7.6.6	Main drains.....	52
7.6.7	Location.....	52
7.7	Pits	52
7.7.1	Benching	52
7.7.2	Pit design	52
7.7.3	Location.....	53
7.7.4	Prefabricated pits	53
7.7.5	In-situ pits.....	53

Infrastructure Design Standard

7.7.6	Capacity	53
7.7.7	Covers.....	53
7.7.8	Litter collection	54
7.8	Subsoil drainage.....	54
7.9	Drainage swales/table drains.....	54
7.10	Stormwater discharge	54
7.11	Scour protection	55
Table 12 - Gabion sizing		55
7.12	Property drainage	55
7.12.1	General	55
7.12.2	Inter allotment drainage.....	55
7.12.3	Stormwater absorption	56
7.12.3.1	Permitted Use.....	56
7.12.3.2	Trench Location and Layout	56
7.12.3.3	Required Capacity	56
Table 13 - Absorption trench capacities		56
7.12.4	Charged Systems.....	57
7.12.5	Connection to Council infrastructure	57
7.13	Major system structures	57
7.14	Pump stations.....	57
7.15	Easements.....	57
7.16	Submission requirements.....	58
7.17	Additional reference material	58
8	RURAL DRAINAGE	59
8.1	Objectives	59
8.2	General	59
8.3	Requirements.....	59
8.4	Minor drainage	60
Table 14 – Rural drainage culvert ARI capacities		60
8.5	Major drainage	60

Infrastructure Design Standard

Figure 1 – Rural major open drains minimum width of easements 61

9	LARGE SCALE STORMWATER DETENTION	62
9.1	Objectives	62
9.2	The use of drainage basins for public open space purposes	62
9.3	General	63
9.4	Larger detention basin design requirements	63
9.4.1	Location and siting	63
9.4.2	Design criteria	64
9.4.3	Inlet structures	64
9.4.4	Low flow pipes	65
9.4.5	Overflow systems	65
9.4.6	Depth of detention basins	65
9.4.7	Batter slopes in earthen basins	65
9.4.8	Access requirements	66
9.4.9	Risk analysis	66
9.4.10	Fencing and security	66
9.4.11	Landscaping	66
9.4.12	Maintenance	66
10	SMALL DETENTION SYSTEMS	68
10.1	Objectives	68
10.2	General	68
10.3	Requirements	69
10.3.1	General	69
10.3.2	Specific design requirements	69
10.3.2.1	Time of concentration	70
10.3.2.2	Approved types of on-site detention	70
11	STORMWATER TREATMENT	71
11.1	Objectives	71
11.2	General	71
11.3	Requirements	72

Infrastructure Design Standard

11.3.1	General Requirements	72
11.3.2	Gross pollutant traps	73
11.3.3	Bioretention swales	73
11.3.4	Bioretention basins and rain gardens	74
11.3.5	Vegetated swales/grass swales/buffer strips.....	74
11.3.6	Sand filters	74
11.3.7	Sedimentation basins	74
11.3.8	Ponds and shallow lake systems.....	75
11.3.9	Rainwater tanks.....	76
12	STORMWATER DISCHARGE POINTS.....	77
12.1	Objectives	77
12.2	General	77
12.3	Requirements.....	78
13	ASSOCIATED INFRASTRUCTURE	79
13.1	Objectives	79
13.2	General	79
13.3	Telecommunications	79
13.4	Water and sewer	79
13.5	Electrical.....	80
14	PUBLIC LIGHTING	81
14.1	Objectives	81
14.2	Provision for public lighting	81
14.3	Lighting design	81
14.4	Pre-submission requirements	82
15	TABLES	83
16	APPENDIX A - STORMWATER	84
	Table 15 - IFD zone 1 data	85
	Table 16 - IFD zone 2 data	86

Infrastructure Design Standard

Table 17 - IFD zone 3 data	87
Table 18 - IFD zone 4 data	88
Figure 3 - Runoff coefficients	89
Figure 4 - Channel flow times	90
Figure 5 - Kinematic wave – overland flow times - 1 & 5 year ARI	91
Figure 6 - Kinematic wave – overland flow times - 20 & 100 year ARI	92
Figure 7 - Pipe flow discharge	93
Figure 8 – Gutter flow capacity – 1% crossfall	94
Figure 9 – Gutter flow capacity – 3% crossfall	95
Figure 10 – Gutter flow capacity – 1% crossfall	96
Figure 11 – Average pit head loss factors	97
Table 19 – Hydrological design sheet 1	98
Table 20 – Hydrological design sheet 2	99
Table 21 – Hydrological design sheet 3	100
Table 22 – Hydraulic design sheet	101
17 APPENDIX B – INFORMATION TO BE SHOWN ON PLANS	102
17.1 Minimum requirements for all plans	102
17.2 Road layout plans.....	102
17.3 Road longitudinal plans	103
17.4 Road cross-section plans	103
17.5 Typical road cross-sections	104
17.6 Intersection and cul-de-sac details	104
17.7 Drainage layout plans	105
17.8 Drainage longitudinal sections.....	105
17.9 Drainage detention and treatment drawings	106
17.10 Detail drawings	107
17.11 Landscape plans.....	107
17.12 Master services plans	107
18 APPENDIX C – COUNCIL STANDARD DRAWINGS	108
19 APPENDIX D – VERSION CONTROL.....	109

Infrastructure Design Standard

20	APPENDIX E – DESIGN CHECKLISTS AND FORMS.....	110
	20.1	
	Design Engineer’s Checklist #1 Construction Certificate...	111

Infrastructure Design Standard

1 Introduction

1.1 General

Eurobodalla Shire Council manages approximately \$1.25 billion worth of public assets. This includes infrastructure that is dedicated to the public as part of construction activities within the Eurobodalla Shire. These assets can run into the tens of millions of dollars per annum.

Council's Infrastructure Design Standards (IDS) details the requirements for the design of infrastructure undertaken on Council, Crown or private land within the Eurobodalla Shire. This will ensure that the quality of the assets received and subsequently maintained by Council meet a minimum design standard.

Eurobodalla Shire Council has developed this IDS to be used in conjunction with AUS-SPEC and Austroads design guidelines.

1.2 Innovation and changing technologies

Eurobodalla Shire Council may give consideration to adopting and approving innovative solutions and using new technologies where it can be demonstrated to Council, that the objectives of the IDS have been satisfied although the specific technical provisions may not have been met.

Infrastructure Design Standard

1.3 Definitions

Access roads	The primary purpose is to provide access to individual properties.
Activity centre	Urban planning term for those places that are vibrant hubs where people shop work, meet, relax and often live.
AHD	Australian Height Datum: The datum surface to which all vertical control for mapping is referred. Relates to mean sea level (0.00m AHD) of 30 tide gauges around Australia's coastline.
AEP	Annual Exceedance Probability: The probability of exceedance of a given discharge within a period of one (1) year.
ARI	Average Recurrence Interval: The average or expected value of the period between exceedance of a given event or discharge. This is usually calculated as the reciprocal of the AEP.
AR&R	Australian Rainfall and Runoff 1987: 2001 Reprint.
Approach sight distance	Relates to the ability of drivers to observe the roadway layout at an anticipated approach speed.
Batter	The uniform side slope of walls, banks, cuttings, etc. Usually expressed as a ratio of vertical to horizontal (eg 1V: 6H).
Carriageway	That portion of a road or bridge devoted particularly to the use of vehicles, that is between guide posts, kerbs, or barriers where these are provided, inclusive of shoulders and auxiliary lanes.
Catchment area	The limits from where surface runoff will make its way, either by natural or man-made paths, to a given point.
CBR	Californian Bearing Ratio
Clear zone	Area adjacent to traffic lanes which are to be kept free from features that would be potentially hazardous to errant vehicles.
Collector roads	Carries higher volumes of traffic collected from lower order roads. Access to individual sites may still be permitted. May also be a bus route.
Consultant	Person or company appointed by a developer to provide expert and technical services and/or liaise with Council.
Council	Refers to Eurobodalla Shire Council.
Crossfall	The slope of the surface of a carriageway measured normal (perpendicular) to the design or road centreline.
Cycleway	Portion of a road or footpath for the exclusive use of cyclists.
DBYD	Dial Before You Dig.

Infrastructure Design Standard

DCP	Development Control Plan.
IDS	Infrastructure Design Standard.
Design speed	A speed fixed for the design and correlation of those geometric features of a carriageway that influence safe vehicle operation.
Desired speed	See also operating speed. The speed over a section of a road adopted by a driver as influenced by the road geometry and other environmental factors.
Developer(s)	Person or company who owns the development.
Development	The undertaking of building, constructing, engineering, mining or other operations in, over or under the land or the making of any activity material change in the use of any building or other land.
Distributor Road	Main function is the convenient flow of traffic generated by an overall development or to link local communities. Direct access should not be provided for single allotments. On rural roads, access may be permitted subject to provision of an appropriate intersection treatment and clustering of accesses into a single access road.DLPDefects Liability Period.
EDD	Extended Design Domain. The design domain for the assessment of existing roads. EDD is a range of values below the lower bound of the NDD.
EPA	Environment Protection Authority.
Footpath	The paved concrete section in a verge.
Greenfield Site	Land not previously developed, ie in a natural or agricultural state
GPT	Gross Pollutant Trap.
HGL	Hydraulic Grade Line.
Hold point	Mandatory verification position beyond which work cannot proceed without designated authorisation from the PCA.
Horizontal alignment	The bringing together of the straights and curves in the plan view of a carriageway. It is a series of tangents and curves that may or may not be connected by transition curves.
IFD	Intensity Frequency Duration
Landform	The type and shape of terrain, usually including topography, geological characteristics, coastlines, rivers and water bodies.
LATM	Local Area Traffic Management.
Legibility distance	The maximum distance that the various types of traffic control signs or devices can clearly be seen under normal operating conditions and where there is no restriction to the line of sight.
Level	See RL

Infrastructure Design Standard

Local roads	The dominant feature is low traffic volumes. In urban areas this is typically combined with low vehicle speeds and easy pedestrian and cycle movementsLPI Land and Property Information
Min gap sight distance	Critical acceptance gap that drivers are prepared to accept when undertaking a crossing or turning manoeuvre at intersections.
MUSIC	Model for Urban Stormwater Improvement Conceptualisation. Computer software tool that simulates stormwater catchment behaviour. For the purpose of Water Quality Assessment.
NDD	Normal Design Domain. The design domain for a new road is referred to as the Normal Design Domain. The extent of NDD defines the normal limits for the values of parameters that have traditionally been selected for new roads.
ODP	Outline Development Plan
Operating speed	see design speed.
Outer separator	The portion of the road reserve separating a through carriageway from a service road.
Pathway	A public way reserved for the movement of pedestrians and of manually propelled vehicles.
Pavement	The portion of a carriageway placed above the sub-grade for the support of, and to form a running surface for, vehicular traffic.
PCA	Principle Certifying Authority.
Pedestrian	A person travelling on foot within a Council reserve
Plan transition	The length over which widening and shift is developed from the 'tangent-spiral' point to the 'spiral-curve' point; ie, the length between the tangent and the curve.
PMF	Probable Maximum Flood
PMP	Possible Maximum Precipitation
POS	Private Open Space
Pre-development	State of a site immediately prior to renovation or redevelopment
Private road	A road in private ownership
Reaction time	The time taken for a driver to perceive and react to a particular stimulus and take appropriate action. It is measured in seconds.
Regional roads	Links communities. No direct access from road to individual properties. All lots should be serviced via roads built off regional roads with an appropriate intersection treatment.
RFS	Rural Fire Service
RL	Reduced Level: a calculated elevation in relation to a particular datum. For all major works; those involving connections to

Infrastructure Design Standard

	Council's sewer or stormwater and; development affected by flooding/sea level rise, the datum is to be AHD.
Road network	A framework for movement by other modes, including pedestrian, bicycle and bus, and plays a vital role in supporting neighbourhoods and town centres.
Road reserve	The strip of public land between abutting property boundaries, specifically gazetted for the provision of public right-of-way. It includes the road carriageway, as well as footpaths, verges and landscape.
Roundabout	A form of intersection channelisation, whereby traffic circulates clockwise around a central island and all entering traffic is required to give way to traffic on the circulating roadway.
SISD	Safe Intersection Sight Distance. An overall check that vehicles utilising the intersection have sufficient visibility to allow reaction and deceleration so as to provide adequate stopping distance in potential collision situations.
SELLS	South East Local Lands Services (formerly Catchment Management Authority).
Service road	A roadway parallel to and separated from an arterial road to service adjacent property. They are usually continuous.
Shared pathway	A public concrete footway reserved for the movement of pedestrians, bicycles and scooters 2.5m wide
Shoulder	The portion of formed carriageway that is adjacent to the traffic lanes and flush with the surface of the pavement.
Shoulder width	Measurement taken from the outer edge of the traffic lane to the edge of usable carriageway and excludes any berm, verge, rounding or extra width provided to accommodate guideposts and guard fencing.
Side friction factor (f)	A measure of the frictional force between the pavement and the vehicle tyre.
Sight distance	The distance, measured along the carriageway, over which the visibility occurs between the driver and an object or between two drivers at specific heights above the carriageway in their lane of travel.
Speed (85 th percentile)	The speed at or below which 85% of the vehicles travel.
SSD	Stopping Sight Distance. The sum of the braking distance and the distance the vehicle travels at a design speed during a reaction time of 2.5 seconds.
State highways	RMS controlled road

Infrastructure Design Standard

Superelevation	A slope on a curved pavement selected so as to enhance forces assisting a vehicle to maintain a circular path.
The Act	Environmental Planning and Assessment Act 1979.
TIAR	Traffic Impact Assessment Report
TGSI	Tactile Ground Surface Indicators
TMAR	Traffic Management Assessment Report
Traffic lane	That part of the roadway set aside for one-way movement of a single stream of vehicles.
Traffic lane width	Traffic lanes are measured to the face of the kerb or to the lane line for multi-lane roads or roads with shoulders.
Verge	That part of the road reserve between the carriageway and the road reserve boundary. It may accommodate public utilities, footpaths, stormwater flows, street lighting poles and plantings.
Verge (rural)	Defined area of the formation in rural roads outside the shoulder to the top of the batter slope.
Vertical alignment	The longitudinal profile along the centreline of a road consisting of series of grades and vertical curves.
WSUD	Water Sensitive Urban Design. The integration of urban water cycle management within planning.

Infrastructure Design Standard

1.4 Design requirements

1.5 Objectives

The objectives of these design requirements are to ensure:

- Expediency for developers by providing clear guidelines regarding the engineering requirements of Council
- That new and upgraded infrastructure is of consistent standard within the Council area and generally consistent with neighbouring local government areas
- That the works are designed so they will fulfil the purpose for which they are intended
- That minimum design standards are achieved and that works meet Council's legislative obligations
- That community amenity will be improved through development
- That environmental, public and employee risk during and after development is considered
- That maintenance requirements are considered at the planning and design stages
- All relevant statutory authorities/stakeholders have been consulted and their requirements have been considered in the design.

1.6 General

Comprehensive design criteria included in this IDS conveys engineering requirements for delivery of design, construction and acceptance of roads and drainage infrastructure, while considering local conditions and the requirements of Council.

For developer's representatives this IDS provides the basis for expedient approvals of works built by developers for incorporation into Council's controlled and maintained infrastructure systems.

This IDS provides the basis of engineering design in association with an application for Council approval. This includes but is not limited to construction certificates; development approvals; Section 68 approvals and Section 138 approvals.

1.7 Pre-design site inspection

A pre-design site inspection is undertaken prior to any detailed design work commencing unless otherwise agreed.

For designers undertaking works on behalf of developers, it is recommended that a pre-design site inspection should be held with a representative from Council's Engineering Development Services to discuss specific issues and requirements for the site and surrounds.

Infrastructure Design Standard

1.8 Variation from design specifications

Any proposal to deviate from this IDS at any stage of the works, shall be made in writing with supporting reasons and must have written approval from Council's Engineering Development Services prior to commencement of any work involving the proposed variation.

Design variations may require amendment of the development consent/construction certificate. Please discuss any variation with Council staff to determine if this is required.

Note: Variations approved for some subdivisions or developments do not imply approval for other current or future proposals.

Infrastructure Design Standard

2 Documentation

2.1 Objectives

The objectives of these documentation requirements are:

- To provide consistency in the presentation of design information
- To eliminate duplication of data entry into various record systems
- To provide a work as executed record of Council's assets.

2.2 Plans

Plans will be prepared as outlined in the following sections. Electronic submissions of plans will be such that any reproduction from these files will achieve an exact duplicate of any hardcopy submission.

2.2.1 Sheet Size

Plans shall be submitted on A1 or A3 sheets that comply with AS 1100 Part 3.

Electronic copies shall be in drawing (.dwg) and pdf format.

2.2.2 Scales

For general consultation prior to development consent, plans may be submitted as A1 or A3 sheets. When requesting approval of conceptual layout, construction certificate design approval or providing works as executed (WAE) information, scales and sheet sizes are to be as per Table 1 – Acceptable Scales and Sheet Sizes.

Plan type	Conceptual layout approval	Construction Certificate and WAE approval
Sheet size	A3	A1
Lot layout	1:1000	1:500
Roads plan	1:1000	Longsection – 1:500 (horiz) and 1:100 (vert) X-section – 1:100 and 1:50 or 1:100
Intersection plans	1:200 or 1:250	1:200 or 1:100
Drainage plans	1:100	1:500 (horiz) and 1:100 (vert)
Details		1:10 or 1:25

Table 1 – Acceptable scales and sheet sizes

2.2.3 Datum

All levels will be to Australian Height Datum (AHD). Plans will nominate a minimum of two (2) permanent survey marks (PM) and their respective numbers/identification and levels, and any temporary benchmarks (TBM) relevant to the works. Where it is not possible to nominate two survey marks, by agreement, Council may allow the use of only one survey mark.

Infrastructure Design Standard

AHD may not be required for rural works in isolated rural areas.

For subdivisions, the plans will nominate all the permanent survey marks and their respective numbers/identification created.

The origin of all road chainage will be nominated in the plans. Road chainages shall generally commence at clearly designated and identifiable locations.

2.2.4 Standard details

All construction details will comply with Appendix C – Council standard drawings. Where special structures or modifications to standard drawings are required, details of such works shall be submitted with the detailed construction plans for design approval.

2.2.5 Drawing numbers

Plans should reference development consent numbers. As a minimum, the development consent number will be clearly shown on the cover or face sheet of any drawing set and be contained within the title block of each drawing.

Council will provide Council plan numbers for any plans which require it. Plans will also include Council file number/s and development consent number.

2.3 Standard drawings

The design engineer will adopt details as shown on Council Standard Drawings where possible. While standard infrastructure is considered highly, the standard drawings will only be used where the item/structure and application is considered standard. The standard drawings are not to be used in lieu of responsibly engineered and detailed structures. Where the standard drawings are not considered appropriate for the application, variations from the standard details will be fully documented to Council's satisfaction. Cross referencing standard drawings with variations made by note, will only be accepted where those variations are considered minor and where directions are clear.

Council Standard Drawings are available in Appendix C – Council standard drawings.

It is the design engineer's responsibility to ensure that the standard drawing used is correct for the application and consultation with Council's Engineering Development Services may be necessary.

2.4 Specifications

Project specifications will ensure that all works undertaken will meet the requirements of Council, and that there are no outstanding liabilities when the projects are handed over at completion.

Refer also to Council's Construction Specifications.

Specification for assets must ensure that the design life as listed below can be achieved with industry standard maintenance:

Infrastructure Design Standard

- Concrete structures generally 80 years.
- Bridges
 - Concrete 100 years
 - Steel 80 years
 - Timber 50 years.
- Buildings/structures 50 years.

Road pavement design life – refer to Section 3.7 – Pavement design

2.5 Information to be shown on plans

The design engineer is responsible for ensuring that information on plans is shown in sufficient detail to enable works to be constructed in accordance with its design intent and as approved by Council. Information shown on plans will include, but is not necessarily limited to, those items listed in Appendix B - Information to be shown on plans.

Each sheet is to include the following statement, signed and dated by the design engineer:

“These plans submitted for a construction certificate in association with {insert Development Application No.}, have been prepared in accordance with the relevant sections of Council’s Development Design Specification Version”

Infrastructure Design Standard

3 Design of roads

3.1 Objectives

The objectives of the design of roads requirements are:

- To develop a network and alignment that balances the existing and future requirements
- To provide a serviceable pavement for the specified lifetime with minimal maintenance
- To ensure that staged construction methods are planned to meet the immediate, medium term and ultimate pavement and drainage design requirements
- To provide smooth, safe, trafficable horizontal and vertical alignments, and adequate sight distance, with consideration being given to road classification requirements, road users and utilities.

3.2 General

Road design shall be based on sound engineering practice following the general principles of Austroads Guidelines and any RMS supplement to those guidelines, NATSPEC and the RMS Road Design Guidelines, in addition to criteria outlined within this IDS.

Road design plans will be prepared in accordance with Appendix B – Information to be shown on Plans.

3.3 Urban roads

The design of roads (and allotment accesses - refer to Section 3.9 Vehicular access) will meet or exceed the requirements of the RMS, this IDS and any relevant Acts, Regulations and Australian Standards.

3.3.1 Road classification

The classification of residential streets within any development shall be generally in accordance Table 3 - Urban Street/Road Characteristics found within 3.3.2 – Road /street characteristics and road reserve widths.

The road classification referred to within this IDS relate specifically to the design and construction of new or upgraded roads.

Note: Access lanes, refer to Table 3 – Urban street/road characteristics, are not acceptable as Council roads. Existing access lanes are to be upgraded to these specifications as warranted by future development. Roads of width and function similar to access lanes may be approved as private roads or common property, however specific treatment of fencing, paving, etc, may be required by Council. It is recommended that negotiation of this issue be addressed as early as possible in the planning process.

Infrastructure Design Standard

Ultimate traffic volumes for road classification and road design will be based upon approved multipliers of existing traffic movements (measured), through traffic and an estimate of traffic generated by proposed and future development. Estimated traffic volumes for undeveloped areas will be based upon:

- Residential allotments 12 vehicle movements per day (vpd) per lot
- Commercial/industrial to be determined on a case by case basis utilising the RMS Guide to Traffic Generating Developments 2002.

Where alternative traffic generation assumptions are used in the preparation of a Traffic Impact Study, details of these alternatives shall be provided to Council for approval.

Where Council holds traffic count data on relevant roads, this information will be made available to the design engineer. In some instances, the developer may be asked to undertake additional traffic count data collection on affected roads to ascertain pre-development traffic volumes and types. This will generally only be asked of the developer when traffic count data is greater than three years old or significant development has taken place since traffic count data was last collected. Where traffic volumes and type vary seasonally, the design engineer will use data conservatively and clearly present assumptions with the request for approval of functional layout.

3.3.2 Road/street characteristics and road reserve widths

The classification, function and general composition of roads and streets within any development are detailed in Table 2 – Urban street/road characteristics.

Road reserve widths must be sufficient to accommodate the road carriageway, required services with approved clearances, pedestrian and bicycle access, parking, landscaping, drainage and bus routes. Should the development design incorporate the Water Sensitive Urban Design (WSUD) principles the road reserve may need to be further increased.

Minimum road reserve widths in urban residential developments shall be as detailed in Table 3 – Urban street/road characteristics.

Lesser width industrial road reserve may be permitted for short industrial cul-de-sacs however turning at the cul-de-sac head will not be compromised.

Minimum road reserve widths will not be allowed where they compromise the provision and standard in relation to footpath, bus, bicycle and pedestrian provisions.

Road reserve boundaries may be curved around cul-de-sacs but where they are to be fenced as chords, the chords should not be less than 10m. Where a number of such chords occur adjacent to each other, they should, as far as possible, be practically equal.

Infrastructure Design Standard

Street type	Indicative maximum traffic volume ⁽¹⁾ vpd	Maximum speed ⁽²⁾ kph	Carriageway width ^(3 & 4) metre	Minimum road reserve width ^(5 & 6) metre	Parking provision within carriageway ⁽³⁾	Pedestrian/cycle provision within road reserve ^{(7) (11)} metre	Kerb and gutter ^{(4) &(5)}
Dual occupancy access driveways ⁽¹⁰⁾	NA	NA	3	NA		NA	
Battle-axe access driveways ⁽¹¹⁾	NA	NA	3	4m		NA	
Right of Way ⁽⁹⁾	60	50	4 minimum	10m			
Access street	<200	40	7.5 (min length 50m, max length 150m)	17	Carriageway	1.5 footpath on 1 side of road	Layback ⁽⁶⁾
Local street with WSUD	<1000	50	7.5m	18.5m	carriageway	1.5 footpath on 1 side of road	Edge-strip
Local street (not bus route)	<1000	50	7.5m	18.5m	Carriageway	1.5m Footpath on 1 side of road	Layback ⁽⁶⁾
Local street (bus route)	<1000	50	7.5	18.5	Carriageway 2.5 wide indented bus bays	1.5 footpath on both sides of road	Layback ⁽⁶⁾
Collector street	<2000 – with access to allotments	50 ⁽⁷⁾	12.5 (refer to parking provisions)	18.5 (no bus bay)	2.5 wide ⁽⁸⁾ indented parking and bus bays not more than 75m apart	1.5 footpath on 1 side of road, 2.5 cyclepath on other side of road	Layback
Distributor road	>2000 – no allotment access	60	Special design	25m	No parking on carriageway ⁽⁸⁾	2.5m cyclepath on 1 side of road	Barrier kerb
Industrial/business ⁽⁸⁾			12.5m	25m	Both sides of carriageway		Barrier kerb

Table 2 – Urban street/road characteristics

Infrastructure Design Standard

Notes:

- (1) For single dwelling allotments apply traffic generation rate of 12 vpd per allotment (equivalent to approximately 1 vph in peak hour) unless a lower rate can be demonstrated. A lower rate of 7 vpd can be applied to multi-unit dwellings based on RMS Guide to Traffic Generating Development.
- (2) See RMS Road Design Guidelines on designing for specific operating speeds.
- (3) Widening required at bends to allow for wider vehicle paths (Austroads Turning Templates).
- (4) Width of carriageway is between kerb inverts or to the centre line of the edge strips.
- (5) Application of WSUD to edge control of pavement to be considered at all times, all roads to be provided with edge strips as a minimum, with roll-over kerbs to be used on tight radius curves to define travel paths. Larger road reserves may be required to contain WSUD within the reserve.
- (6) Barrier kerbing may be used if required for drainage purposes without reducing carriageway width.
- (7) Reduced speeds are required at designated pedestrian/cyclepath crossings.
- (8) If parking is required, it is to be provided in an off-street parking area which can be exited in a forward direction.
- (9) Right of ways are to meet minimum requirements set by NSW Rural Fire Service in bushfire prone areas, AS2419 (*Fire Hydrant Installations*) in reticulated water supply area, and AS2890.
- (10) All driveways are to provide passing bays every 50m or in accordance with merit based assessment.
- (11) Footpaths are to be located in accordance with Eurobodalla Shared Pathway Strategy 2010.

Note: Many elements are inter-related, therefore variation from any particular characteristic may require changes to others.

Infrastructure Design Standard

3.3.3 Widths and treatments of other reserves

The widths and treatments of other reserves will be determined utilising good urban design principles such as Safer by Design Guidelines, the Healthy Active by Design tool and other relevant guidelines to reduce crime, improve public safety and enhance the local amenity.

Where pedestrian and/or bicycle access reserves are incorporated into developments the minimum reserve width shall contain the path and provide 2.0m clearance on either side. The reserve may need to be of greater width for reserves deeper than one average allotment or to provide line of sight to meet objectives of safer by design.

For all proposed reserves a landscaping and lighting plan shall be provided in accordance with the IDS and as approved by Council.

Where reserves are required specifically for provision of services other than those under Council's responsibility, those reserves shall be vested with the relevant authority.

3.3.4 Road geometry

The geometric design of arterial roads will be in accordance with Austroads and RMS requirements. For roads that are Council's responsibility, road geometry will provide sufficient space such that emergency service vehicles, waste collection vehicles and street-cleaning vehicles may carry out their functions while travelling in a forward-only direction throughout the development. Cul-de-sacs will be of bowl geometry.

"T" or "Y" cul-de-sac heads are not permitted.

Staging of works shall not negate this requirement and temporary turning areas may need to be established between development stages including carriageway easements as required.

Parking, bicycle and bus requirements which may impact upon the minimum widths and adequacy for these functions shall be demonstrated at the approval of functional layout stage.

3.3.5 Sight distances

Consideration will be given to sight distances, particularly at street intersections and on crest vertical curves. Reference will be made to the relevant Austroads Guide and any RMS supplement to those guidelines as follows:

- General road design Austroads Guide to Road Design Part 3: Geometric Design
- Intersections – Austroads Guide to Road Design Part 4A: Signalised and Unsignalised Intersections
- Roundabouts – Austroads Guide to Road Design Part 4B: Roundabouts.

Landscaping plans will be prepared with consideration to sight distance requirements, as will any proposal for Estate Entrance Structures or thresholds. These structures are to be created off the road reserve.

Plans submitted for approval will show all existing and proposed features in sufficient detail to demonstrate that appropriate sight distances are achieved.

Infrastructure Design Standard

3.3.6 Vertical alignment and vertical curve requirements

Road design grading will be extended a minimum of 100m (increasing with road order up to 200m for distributor roads) beyond the end of the street where such street is to be extended in the future. Where new roads meet existing roads the designer check the grading for a distance of 50m, or as directed by Council, to check that roads match well and that no abrupt change in grade occurs - refer to Table 4 – Limiting longitudinal grades.

Vertical curves on subdivisional streets will be designed to 60kph. Horizontal alignment will provide Stopping Sight Distances for the following speed values:

Type of street	Target street speed (kph)
Access street	60
Local street	60
Collector road	60
Distributor road	80*

* Dependent on warranted speed limits

Table 3 – Sight stopping distance target speeds

Vertical curves are to be provided at all changes of grade in road centreline greater than 1.0%, or changes in grade of kerb and gutter greater than 0.5%. Vertical curves will be of suitable lengths to provide design characteristics in accordance with speed values as detailed in Table 3 – Sight stopping distance target speeds. Vertical curves should not coincide with the horizontal curves wherever practical. Vertical curve design guidelines as set out in Austroads Guide to Road Design Part 3: Geometric Design and any RMS supplement to those guidelines, will apply to urban conditions in the relevant ranges.

3.3.7 Limiting longitudinal gradients

Road grades will fall within the limits shown in Table 4 – Limiting longitudinal grades where kerb and gutter is used.

Type of grade	Grade
Desirable minimum grade	1% (1:100)
Absolute minimum grade	0.5% (1:200)
Desirable maximum grade	10% (1:10)
Absolute maximum grade	18% (1:5.56)

Table 4 – Limiting longitudinal grades

On curves, the kerb and gutter grades are to be calculated along the outer kerb for minimum grade and along the inner kerb when grades approach maximum limits.

The longitudinal grades of all roads should be designed to maximise the accessibility of the adjacent footpath and to be considered at the conceptual master plan layout stage. Subdivision layouts should be arranged to maintain requirements of AS 1428.2 as much as practicable.

Infrastructure Design Standard

At intersections, each kerb is to be graded individually around the return and designed to match the kerb grade of the adjoining street and to follow as closely as possible the vertical curve produced on the pavement by designing to match the through street.

3.3.8 Vehicle turning movements

Vehicle turning movements are to be designed using the Austroads Design Vehicle and Turning Path templates. Road space should be provided so that the design vehicle is able to negotiate a left turn from the left lane without crossing adjacent lanes and without the need to reverse to complete the turning movement. Check vehicles may impinge upon adjacent lanes as they represent infrequent vehicles accessing local streets, such as articulated vehicles delivering building materials in new estates or furniture carrying vehicles.

The intersection design will be so that a 600mm clearance for above ground structures is applied to the total swept path of the design vehicle and not just to the wheel path. Vehicle accesses and driveways are NOT to be used for turning movements. All roadways, right-of-ways and vehicle crossings are to be designed to accommodate a standard vehicle (car).

Turning movement plans will be provided to Council with the approval of functional layout submission.

3.3.9 Cross section profiles

Cross sections shall accord with road carriageway and road reserve widths nominated within this IDS. Typical cross sections should be included in the documentation and should nominate:

- Type of kerb and gutter
- Pavement design including material type and depth
- Surface details
- Subsoil drainage, if required
- Typical footpath offsets
- Typical service corridors
- Typical landscaping corridors
- Crossfalls.

The normal crossfall on bituminous pavements should be 4%. Should design speeds require super-elevation of horizontal curves, design of super-elevation should be based on the current Austroads design policy for urban roads.

Should crossfalls of greater than 4% at intersections or horizontal curves be proposed, approval should be sought from Council's Engineering Development Services.

The relative change in grade of kerb line and centreline is not to exceed 0.5%.

Central spoon drains in the road pavement are undesirable and will only be permitted for road pavements that will be incorporated as common property. This does not apply to fully concreted pavements with crossfall to the centre of the road with centrally grated pits.

Footpath crossfalls shall be 1:50 desirable and 1:40 maximum, unless approved.

Infrastructure Design Standard

Preferred footpath alignments will be 1m offset maximum from the back of kerb, unless approved.

Verge crossfalls between footpath and back of kerb will be 1:40 desirable maximum. Verge crossfalls between footpaths and property boundaries will be a maximum of 1:8 and shall extend into properties at the same grade for a nominal distance of 500mm. Should steeper verges be proposed, the designer will demonstrate that car access can be provided to affected allotments.

Wherever new kerb and gutter or footpath is to be designed adjacent to existing roadways and/or wherever excessive crossfalls occur on either the road pavement or nature strip, all vehicle crossings to allotments shall be checked using standard car templates to ensure that car access can be provided.

Batter slopes will be appropriate for the predominant use of the locality but in areas within the clear zone maximum batter slopes are:

- Desirable: 1:6; maximum 1:4
- Residential area access 1:10 maximum.

Whenever it is impractical to provide batters flatter than the maximum slopes specified, developers will provide special treatment such as retaining walls within the private property boundary.

Unless demonstrated to be impractical, road designs shall be such so as to avoid filling on the low side street alignment.

3.3.10 Kerb and gutter

All urban streets will be designed with a sealed pavement and provided with kerb and gutter unless alternative treatment is integral to a WSUD application.

Kerb and gutter will ensure that adequate and safe access to each allotment is available to vehicles, bicycles and pedestrians, and drainage needs are fulfilled. Kerb and gutter types shall be designed in accordance with Appendix C: Council standard drawings, and with the following:

- Modified semi-mountable kerb and gutter should be used for residential developments. Where barrier kerb and gutter is used, laybacks and vehicle crossovers should be provided at the time of development
- Transition between differing types of kerb and gutter will be either:
 - Immediately after a kerb crossing
 - Over a 3m length after a Kerb Inlet Pit (KIP) where the pit has standard/barrier lintel and the pit is located at the tangent point of the kerb return
- Semi-mountable kerb will be used adjacent to medians and traffic islands
- Subsoil drainage will be required at all roundabouts and medians
- Subsoil drainage will be provided below all kerb and gutter.

Kerb crossings will be designed at approved locations and will comply with Appendix C: Council standard drawings.

Infrastructure Design Standard

Kerb crossings near intersections will be located far enough from the intersection so that each ramp is fully designed to height of back of kerb, as per Council Standard Drawings.

Control joints will be designed as per Appendix C: Council standard drawings.

3.4 Rural roads

3.4.1 General

The following requirements generally apply to new roads and upgrading of existing roads affected by land zoned E4 Environmental Living and R5 Large Lot Residential.

The design and construction of roads and allotment access should meet or exceed the requirements of Austroads, this IDS and any relevant Acts, Regulations and Australian Standards.

New and upgraded roads in E4 and R5 zoned precincts shall be to full road construction standards.

3.4.2 Road reserves

Road reserve widths must be sufficient to accommodate the road carriageway, required services with approved clearances, pedestrian and bicycle access where appropriate, parking, drainage and bus routes where development is significant. Should the development design incorporate WSUD principles, the road reserve may need to be further increased.

Minimum road reserve widths in rural living and low density developments will be 20m, however additional reserve width is encouraged to facilitate landscaping and pedestrian/bicycle facilities.

Splays at intersections will be in accordance with Section 3.5.5 – Splays.

Road type	Indicative maximum traffic volume	Minimum reserve width	Minimum seal width	Minimum shoulder width	Kerb and gutter
Access road (minor)	250vpd	20.0 m	6.5m	0.5m	Refer to 3.4.9
Local road	<1000vpd	25.0m	7.2m	0.6m	Refer to 3.4.9
Collector road	<2000vpd	25.0m	8.0m ⁽⁵⁾	0.75m	Refer to 3.4.9

Table 5 – Rural road characteristics

Notes:

Important: Table 5 must be read in conjunction with the following:

1. These seal widths apply where waste collection vehicles are allowed to travel on the unsealed shoulders of the court bowl, on the condition that the shoulders are designed with full depth pavement
2. These seal widths and kerbs apply where cul-de-sacs include kerbing
3. Classifications and construction of new roads are to be in accordance with Council's Roads Management Plan and Road Asset Management Plan
4. In accordance with Section 94 Contribution Plan – Rural Roads
5. Consideration should be given to the needs of cyclists

Infrastructure Design Standard

3.4.3 Road geometry, horizontal and vertical alignments

The geometric design of rural roads, including horizontal and vertical alignments, is to be based on Austroads Guide to Road Design Part 3: Geometric Design and any RMS supplement to those guidelines, unless otherwise noted within this IDS.

Widths shall be in accordance with Section 9.4.2 – Road Reserves. Further to this, roads in E4 and R5 zoned precincts will provide sufficient space such that emergency service and waste collection vehicles may carry out their functions while travelling in a forward only direction throughout the development. Developments may require provision for school buses. Roads shall be designed such that these vehicles will not need to reverse.

Staging of works shall not negate the requirement for forward only turning and temporary turning areas may need to be established between development stages including carriageway easements as required. This may therefore require temporary table drains around these turning areas.

Where a street is to be extended in the future, road design, grading will be extended a minimum of 100m beyond the end of the street. Where new roads meet existing roads, the designer shall check the grading for a distance of 50m, or as directed by Council, to ensure roads match well and that no abrupt change in grade occurs.

For rural roads on which speeds are influenced by horizontal alignment refer to Table 6 – Typical rural road desired speeds and Austroads: Guide to Road Design Part 3: Geometric Design.

Approx. range of horizontal curve radii (m) ⁽¹⁾	Desired speed (kph) ⁽²⁾ terrain type			
	Flat	Undulating	Hilly	Mountainous
Less than 75	-	-	75	70
75 – 300		90	85	80
150 - 500	110	100 – 110	95	90
Over 300 – 500	110	110	-	-
Over 600 – 700	110 – 120	-	-	-

Table 6 – Typical rural road desired speeds

Notes:

1. Generally representative of road's geometric standard. Not to be used as design values.
2. Desired speed as a function of overall geometric standard and terrain type. It is the speed regarded as acceptable to most drivers in the particular environment, and represented by the 85th percentile speed on unconstrained sections, eg., straights, curves with radii well above those listed.

3.4.4 Sight distances

Adequate horizontal and vertical sight distance should be provided for the design speed in accordance with Austroads Guide to Road Design Part 3: Geometric Design and any RMS supplement to those guidelines. The design speed to be used for a particular road will be the 85th percentile speed, when this exceeds the legal road speed limit for that road. The requirements of Section 3.3.5 – Sight distances should also be met.

Infrastructure Design Standard

Landscaping plans to be prepared with consideration to sight distance requirements, as will any proposal for Estate Entrance Structures or thresholds. These structures are to be created off the road reserve.

3.4.5 Vertical curve requirements

Vertical curve design will generally comply with Austroads Guide to Road Design Part 3: Geometric Design and any RMS supplement to those guidelines. Vertical curves on rural roads shall be designed to provide stopping sight distances for the design speed for the particular road. Vertical curves should coincide with the horizontal curves.

3.4.6 Limiting longitudinal gradients

Rural type roads without kerb and gutter may have a minimum longitudinal grade of 0.5%, unless otherwise agreed in writing. Maximum longitudinal grade for rural roads shall be 15%, unless otherwise agreed, and shall be restricted to a distance of 150m maximum. The maximum longitudinal grade for rural roads adjacent to intersections will be 5%.

3.4.7 Cross section profiles

There will be two lanes of traffic on roads within E4 and R5 zoned precincts.

Cross section design should not be terminated at the property boundaries but should be extended sufficiently to determine cut and fill requirements and to show such on plans.

The normal crossfall on bituminous pavements should be 4%. Should design speeds require super-elevation of horizontal curves, design of super-elevation should be based on Austroads Guide to Road Design Part 3: Geometric Design and any RMS supplement to those guidelines.

Should crossfalls of greater than 4% at intersections or horizontal curves be proposed, approval should be sought from Council's Engineering Development Services.

Batter slopes shall be as is appropriate for the predominant use of the locality and shall be designed with consideration to Clear Zones as defined in Austroads Guide to Road Safety Part 6: Roadside Design, Safety Barriers and any RMS supplement to those guidelines. Areas within the Clear Zone, batter slopes can be as follows:

- Desirable: 1:6; maximum 1:4
- Residential area driveway slopes: 1:8 maximum.

Whenever it is impractical to provide batters flatter than the maximum slopes specified, developers will provide special treatment within the private property boundary and in areas prone to erosion, a proposal is to be submitted for approval to eliminate sediment runoff.

3.4.8 Vehicle turning movements

The design engineer will be responsible for identifying all possible turning movements and make allowance for these in the development design. Turning movements will be shown on plans and provided at Council's request.

Infrastructure Design Standard

3.4.9 Kerb and gutter cut embankments

Where any sections of road are in cut (embankments), the placement of kerb and gutter is required to prevent the scouring of roadside drains - refer to Section 7.9 Drainage Swales/Table Drains

When scour velocities in table drains require protection by rock lining, this treatment is to be replaced by kerb and gutter construction.

3.5 Intersection design

3.5.1 General

Intersections are to be designed so that they function in a safe, convenient and appropriate manner for the type of street and development, and shall be designed in accordance with Austroads Guide to Road Design Part 4A: Non-Signalised and Signalised Intersections and Austroads Guide to Road Design Part 4B: Roundabouts, and any RMS supplement to those guidelines.

Intersections with State, rural or urban roads or National highways are to be designed in accordance with RMS requirements.

The road network will be designed so that at least 90% of dwellings will be within 400m safe walking distance from an existing or proposed bus route and from existing or proposed public open space facilities. Pedestrian path mapping should be provided to support the proposed road network layout.

T-junctions should be adopted in preference to four-way intersections. Where four-way intersections or cross intersections are to be designed, traffic control treatment will be required.

Where staggered T-junctions are to be provided in rural areas, the intersecting roads should be located a minimum distance of twice the stopping distance of the travel speed along the through-road (1.5 second reaction time). Where staggered T-junctions are proposed for rural cross intersections, these arrangements should preferably be of the "right to left" type.

Staggered T-junctions require RMS or RMS delegated Council approval.

Where intersections are in a configuration deemed likely to cause traffic problems, the developer may be required to construct traffic islands or such traffic facilities to provide traffic control and safety. Roads should junction at between 70 and 110 degrees.

3.5.2 Level of treatment

The appropriate level of treatment at intersections will depend on the characteristics of existing and proposed connecting roads. Consideration shall be given to Austroads Guide to Road Design Part 4A: Non-Signalised and Signalised Intersections and any RMS supplement to those guidelines when determining the level of treatment at intersections.

If roundabouts are incorporated into intersections, roundabout will be designed in accordance with Austroads Guide to Road Design Part 4B: Roundabouts and any RMS supplement to those guidelines.

Roundabouts are major traffic control items requiring RMS approval. On Eurobodalla Shire roads, RMS has delegated such approval to Council under a number of conditions.

Infrastructure Design Standard

3.5.3 Special considerations

For intersections where the proportion of over-dimension or large combination vehicles is higher than the normal percentage in the traffic stream the intersection requirements may be more significant. A Traffic Management Strategy should address this issue and make recommendation regarding these intersections.

3.5.4 Intersection spacing

Intersection spacing on State classified roads require RMS approval. Developers are encouraged to discuss access to State arterials early in the DA process.

Intersections will be designed and located to provide a safe environment for all street users, with clear indication of right-of-way priority for pedestrians, cyclists and vehicles.

3.5.5 Splays

Splays of suitable dimensions shall be provided at all corners of all intersections.

At intersections involving at least one collector road (or higher classification) the minimum splay at the intersecting roads shall be 5m x 5m. Otherwise, at intersecting roads of lesser classification, the minimum splay shall be 3.5m x 3.5m.

Larger splays may be required where engineering assessment indicates a need commensurate with traffic safety and the provision of service corridors and trunk drainage.

3.5.6 Kerb returns

At intersections, the minimum kerb return or edge of seal radius will be:

- Residential areas 7.5m
- Industrial/rural areas 12m.

Further to this, kerb radii will be designed based upon turning movement requirements as detailed in Section 3.3.8 – Vehicle Turning Movements.

3.6 Traffic calming

Calming devices such as slow points, chicanes and splitter islands should be designed in accordance with the requirements of the Austroads Guide to Traffic Engineering Management Part 8: Local Area Traffic Management and any RMS supplement to those guidelines.

It should be noted that some traffic calming devices are major traffic control Items requiring special approval. It is the designer's responsibility to obtain the necessary approvals.

Infrastructure Design Standard

Traffic calming devices are to be approved by Council's Engineering Development Services. The following issues need to be addressed as a minimum:

- Streetscape
 - Reduce the linearity of the street by segmentation
 - Avoid continuous long straight lines (eg., kerb lines)
 - Enhance existing landscape character
 - Maximise continuity between existing and new landscape areas.
- Location of devices/changes
 - Devices other than at intersections should be located to be consistent with streetscape requirements
 - Existing street lighting, drainage pits, driveways, and services may decide the exact location of devices
 - Slowing devices are optimally located at spacing's of 100-150m.
- Vehicles
 - Emergency vehicles must be able to reach all residences and properties
 - Local streets with a "feeding" function between arterial roads and minor local streets might be designed for an Austroads Design Single Unit Truck/Bus
 - Where bus routes are involved, buses should be able to pass without mounting kerbs and with minimised discomfort to passengers
 - In newly developing areas where street systems are being developed in line with LATM principles, building construction traffic must be provided for.
- Control of vehicle speeds
 - Maximum vehicle speeds can only be reduced by deviation of the travelled path. Pavement narrowing have only minor effects on average speeds and usually little or no effect on maximum speeds
 - Speed reduction can be achieved using devices that shift vehicle paths laterally (slow points, roundabouts, corners) or vertically (platform intersections, platforms pedestrian/school/bicycle crossings)
 - Speed reduction can be helped by creating a visual environment conducive to lower speeds. This can be achieved by "segmenting" streets into relatively short lengths (less than 300m) using appropriate devices, streetscapes or street alignment to create short sight lines.
- Visibility requirements (sight distance)
 - Adequate critical sight distances should be provided such that evasive action may be taken by either party in a potential conflict situation. Sight distances should relate to likely operating speeds
 - Sight distances to be considered include those of and for pedestrians and cyclists, as well as for others
 - Night time visibility of street features must be adequate. Speed control devices particularly, should be located near existing street lighting if practicable and all street features/furniture should be delineated for night time operation. Additional street lighting shall be provided by the developer at proposed new speed control devices located away from existing street lighting.

Infrastructure Design Standard

- Critical dimensions

Many devices will be designed for the normal use by cars, but with provision (such as mountable kerbs) for large vehicles. Some typical dimensions include:

- Pavement narrowing
- Single lane 3.5m between kerb inverts
- 3.75m between obstructions
- Two lane 5.5m minimum between kerb inverts
- Bicycle lanes (including adjacent pavement narrowing) are to be 1.2m absolute minimum 1m in special circumstances in accordance with Austroads Guide to Road Design Part 3: Geometric Design (Section 4.8) and any RMS supplement to those guidelines
- Width of clear sight path through slowing devices are to be 1.0m maximum ie., the width of the portion of carriageway which does not have its line of sight through the device blocked by streetscape materials, usually vegetation
- Dimensions of mountable areas required for the passage of large vehicles to be determined by appropriate turning templates.

3.7 Pavement design

The minimum depth of flexible or rigid pavement for the proposed pavement and proposed pavement materials shall be determined by design, with the pavement design submitted to Council's Engineering Development Services for consideration. When requested by Council, samples and/or results of geotechnical testing and the source of the pavement material shall be provided. Where a rigid pavement comprising deep lift asphalt and/or stabilisation is proposed a design must be submitted.

3.7.1 Sub-grade analyses

Pavement design will be based on the results of sub-grade analysis, including testing for four (4) day soaked Californian Bearing Ratio (CBR), carried out by a NATA registered testing laboratory. Sub-grade soil samples will be taken at maximum intervals of 200m, at the heads of all cul-de-sacs, at all intersections and at all obvious locations where existing sub-grade material changes suddenly. Core samples will be bored to a minimum depth of 600mm below final road sub-grade level. The soil sample used for laboratory testing will be taken from the core at sub-grade level. Full details of sub-grade test results and core samples including location plan, shall be submitted to Council with the detailed design plans.

Wherever soft sub-grade is encountered the depth to the next solid layer shall be determined by probe.

3.7.2 Flexible road pavements

Flexible road pavement designs shall be in accordance with Austroads Guide to Pavement Technology, 2010. Pavement design shall be carried out using equivalent standard axle loadings based on an average traffic generation rate of 12 vehicles per day per residential lot and a 40 year design life for residential and commercial roads. Pavement design for

Infrastructure Design Standard

industrial roads will be based on an average traffic generation rate of 45 vehicles per day per industrial lot and a 40 year design life.

3.7.3 Concrete street pavements

Concrete street pavement shall be based on Austroads Guide to Pavement Technology 2010 Guide to Structural Design of Road Pavements revised 2006, and Cement and Concrete Association of Australia Guide to Residential Streets and Paths, to a minimum 40 year life span.

3.7.4 Minimum pavement thickness

Notwithstanding any of the above requirements, the pavement thickness shall be a minimum of 300mm for roads in which kerb and gutter is to be designed. The sub base layer shall extend a minimum of 300mm past the rear face of any kerb and/or guttering.

The minimum pavement thickness under the kerb can be reduced to 150mm subject to geotechnical confirmation.

Note: these minimums do not apply to roads serving industrial or commercial areas.

3.7.5 Minimum shoulder thickness

For unkerbed roads, the pavement layer will extend at least to the nominated width of the shoulder and in rural cul-de-sac heads the full pavement thickness is required to extend to the full width of the shoulder - refer to Section 3.4 – Rural Roads.

3.7.6 Pavement sub-base

The typical flexible pavement sub-base will be designed in accordance with Austroads Guide to Pavement Technology, materials to be used subject to Council approval.

3.7.7 Pavement wearing course

The preferred road surface for all urban residential roads (new and upgraded roads), including widened roads and roads which are located in or adjacent to E4 Environmental Living and R5 Large Lot Residential zoned land, will be a two coat bituminous seal. The first coat shall generally be a 14mm nominal size aggregate, followed by a final coat of 7mm aggregate.

New and upgraded roads designed in areas with heritage characteristics may require specific colours of gravel to be used. Liaison with Council's Engineering Development Services and Planning Departments will be required in these instances.

All new and upgraded roads, including widened roads, that are located in or adjacent to commercial or industrial developments shall be sealed with a Type H Asphaltic Concrete of suitable thickness for the expected traffic loading, with the minimum thickness to be 40mm.

All cul-de-sacs shall be sealed with a wearing course of 40mm Type N Asphaltic Concrete of suitable thickness for expected traffic loading, with a minimum thickness to be 40mm.

Infrastructure Design Standard

3.7.8 Connections to existing pavement

Where new pavements abut existing pavements, whether longitudinal or transverse pavement joints, benching of the base course to a minimum width of 300mm will be provided to achieve an effective key-in. Longitudinal joints located along wheel paths should be avoided.

3.8 Traffic control devices

The design engineer will determine any necessary traffic control devices in accordance with Austroads Guide to Traffic Management Part 8: Local Area Traffic Management and any RMS supplement to those guidelines. The supply and installation of traffic control devices will comply with AS 1742 Parts 1-15.

It should be noted that major traffic control items require special approval. It is the designer's responsibility to obtain the necessary approvals - refer to Section 3.6 – Traffic calming.

3.8.1 Signposting and pavement marking

Signposting and pavement marking should be provided to roads, intersections, traffic control devices, cycleways and car parks in accordance with AS 1742 Parts 1–15. Street name plates are to be the standard type, unless otherwise approved in writing.

Styles for signposting will be in accordance with Appendix C – Council standard drawings.

3.8.2 Road safety barriers

Where there is a warrant (eg., an identified hazard in the Clear Zone), where shown on the approved engineering plan or as directed by Council's Engineering Development Services barriers are to be installed in accordance with the Austroads Guide to Road Design Part 6: Roadside Design, Safety and Barriers.

3.9 Vehicular access

Roads should be located and designed so that vehicular access is available to every allotment of a subdivision. Where the natural surface slopes steeply to or from the road, the access to each lot should be given special consideration. The locating of an access is to be avoided if effect to the vertical alignment of the road will occur.

Vehicular access to each and every allotment within a subdivision development shall be provided at the time of development. Vehicle crossings however are not required to be designed at the time of development where mountable or semi mountable kerb and gutter is used, as these may be constructed during later building works when the final location is known.

Where developments include construction of barrier kerb and gutter, a vehicle crossing and layback section in the kerb and gutter shall be provided to each allotment frontage at the time of development.

Infrastructure Design Standard

Vehicle crossings will be designed in accordance with Appendix D – Access driveways and Appendix C – Council standard drawings.

Where property has access to more than one road, access is to be from the lowest order road.

All crossings will be designed with an all-weather concrete or bitumen surface for the section of crossing contained within the road reserve. That portion of the crossing that passes through the footpath zone shall conform to the requirements of AS 1428.1 2009.

3.9.1 Rural vehicle crossings

At the access point a vehicle standing area which is relatively level (maximum grade 5%) with the road pavement for a minimum distance of 7m from the edge of the road/road seal at an approach angle of 70°- 90° is to be provided.

All rural vehicle access crossings shall include a culvert unless the location of the access is at an obvious high point. The minimum width of culvert shall be 4.88m - refer to Appendix B: Information to be shown on plans. All culverts shall have a headwall at each end of the pipe. Trafficable headwalls shall be used wherever the culvert/headwall is located within the Clear Zone - refer to Appendix C - Council standard drawings.

The minimum pipe size varies according to the slope of the terrain. In flat terrain the minimum pipe size is 450mm in E4 and R5 zoned precincts, and pipes shall be laid so that the pipe inlet is 150mm lower than the invert of the table drain. In steeper terrain the minimum pipe size is 375mm where the steeper grades reduce the risk of silting and blockage.

The minimum pipe size is 375mm in low density residential zones where table drain batters are flat enough to allow mowing. In these instances pipes shall be laid such that the pipe invert matches the table drain invert.

Concrete swale crossings can be used where the depth of the table drain is generally less than 350mm deep and the depth times velocity <0.35 . Refer to Appendix C – Council standard drawings.

At existing entrances with either a 300mm or 375mm culvert, new headwalls may be added to the existing culvert as long as the existing pipes are in good condition, are laid at the correct level, and are demonstrated to have sufficient hydraulic capacity.

Culverts will be designed with the following hydraulic capacity:

- 1:5 year ARI capacity before property culvert overtops
- 1:50 year ARI capacity results in overtopping of maximum depth of 300mm
- No water shall encroach on the edge of shoulder on sealed roads or edge of gravel on gravel roads.

Access points are to be determined:

- By providing sight lines in accordance with AS 2890
- Without disturbing tree stability in accordance with AS 4970.

Council shall generally require rural vehicle crossings to be upgraded to meet current standards whenever rural land is subdivided, unless the location of the access is at an

Infrastructure Design Standard

obvious high point. Where a development consent relates to boundary realignment only, there will generally be no engineering requirement for upgrade to accesses, unless the proposed realignment would see a significant change in the use of such access.

3.10 Requirements for dust suppression

Dust suppression works may be required where a proposed new house or an existing dwelling is likely to experience significant detrimental impacts arising from the dust generated by traffic travelling along a gravel road created from either:

- Additional traffic resulting from a proposed development eg., traffic generated from a new piggery or a new subdivision or
- Existing traffic.

Infrastructure Design Standard

4 Mobility and access provisions

4.1 Objectives

The objectives of mobility and access provisions are:

- To promote walking and cycling into daily activities
- To promote universal access within the community
- To promote community health and wellbeing associated with increased physical activity.

4.2 General

The developer shall provide continuous footpaths for all property frontages and sideages in urban residential and commercial developments in accordance with Table 2 – Urban street/road characteristics - refer to Section 3.3.2 – Road /street characteristics & road reserve widths. Developers may also be required to establish connective links to existing footpaths where demand is directly related to the development. Connective links will generally be required of commercial developments to off-site car parking related to the development.

4.3 Requirements

The following requirements apply to footpaths and pedestrian accesses:

- Footpath alignments will be 1m offset from back of kerb
- The minimum footpath width to be 1.5m in residential areas and full verge in Business areas
- The desirable maximum crossfall on footpaths is 1:50 and the absolute maximum crossfall is 1:40, including kerb crossings. Kerb crossings shall be provided in accordance with AS/NZS1428.4, 2009 in locations identified in consultation with Council's Engineering Development Services
- Footpaths shall be constructed of concrete and shall conform to AS/NZS1428.4, 2009.
- Tactile Ground Surface Indicators (TGSi) shall be provided in accordance with AS/NZS1428.4, 2009 at Council's direction
- Footpaths shall slope away from the property boundary and be elevated above the adjacent nature strip. In general, reverse fall on nature strips is undesirable and will only be approved where no other practical alternative is available
- Details of service pits to be located within the footpath or pedestrian areas are to be provided to Council for approval
- Minimum width for shared paths to be 2.5m and designed in accordance with the Austroads Guide to Road Design Part 6A: Pedestrian and Cyclist Paths, 2010 and any RMS supplement to those guidelines. Where a shared path crosses a pedestrian bridge a minimum lateral clearance of 0.5m on both sides of the shared path will be provided where the speed of cyclists is less than 20kph. Where higher bicycle speeds are likely, a minimum lateral clearance of 1m on both sides of the shared path will be provided.

Infrastructure Design Standard

5 Car parking

5.1 Objectives

To ensure that car parking is provided of sufficient number and standard that services residents, visitors, staff, customers, service vehicles and other users.

5.2 General

The number of parking spaces to be provided for any development shall be in accordance with Council's Parking and Access Code or in accordance with an approved TIAR. The design will ensure that parked vehicles do not obstruct the passage of vehicles, do not create traffic hazards or undue pedestrian hazards, and do not detract from the streetscape amenity.

5.3 Requirements

The following parking requirements apply to all developments:

- The parking requirements for normal levels of activity associated with any land use should be accommodated on site and should be located, and of dimensions, that allow convenient and safe access and usage
- All parking, both on and off site, shall be finished with an all-weather seal and line marked. Gravel surfaces shall only be permitted with written permission of the Coordinator of Council's Engineering Development Services
- The layout and access arrangements for all on-street and off-street parking areas should conform to Austroads Guide to Traffic Management: Part 11 Parking or AS 2890.1 – 2004, AS 2890.2 – 2002, AS 2890.3, AS 2890.5 -1993 and AS 2890.6
- The number of on-site parking and off-site parking spaces for non-residential land uses shall conform to parking standards as specified on the development consent where applicable, or in accordance with Council's relevant parking strategies
- Lighting is to be provided to the satisfaction of Council's Engineering Development Services and in accordance with AS 1158
- Loading/unloading requirements should consider forklift/ pedestrian conflicts and other movements on the site.

In addition to the above, the following parking requirements apply to all residential subdivisions developments:

- The availability of parking should be adequate to minimise the possibility of driveway access being obstructed by cars parked on the opposite side of the street
- All verge spaces and indented parking will be designed to withstand the loads and manoeuvring stresses of vehicles expected to use those spaces
- The measures proposed to ensure the dedicated resident parking and casual visitor access is limited to people proposing to use the development.

Infrastructure Design Standard

In addition to the general requirements, the following parking requirements apply to all on-site parking:

- The pavement designer will make specific allowance for traffic load concentrations within carpark areas eg., entrances/exits
- All loading/unloading zones are to be constructed of concrete pavement or concrete segmental pavers to resist damage from diesel and fuel spills. Paving should be mottled to mask spills.

Infrastructure Design Standard

6 Earthworks and Lot Filling

6.1 Objectives

The objectives of the earthworks and lot filling requirements are:

- To ensure that development does not cause or aggravate flooding of other properties by filling land or undertaking other flood diversion works
- To ensure that buildings are located on a natural surface above the 1% flood level or on approved filled ground
- To ensure earthworks and lot filling activities do not result in the spread of noxious weeds
- To ensure that the recommendations of SELLS (South East Local Land Services) or other relevant agencies or organisations are complied with
- To ensure that earthworks and lot filling works does not result in erosion, dust, mud or debris leaving the site
- To maintain privacy and security of adjacent landowners.

6.2 General

Typical earthworks may include lot filling or the construction of building pads, dams, open drainage systems, levies, access tracks, flood protection devices overland flow paths and vegetation removal.

Approval of engineering plans by Council's Engineering Development Services relates to the suitability of earthworks to achieve road and drainage systems to the satisfaction of Council. Engineering approval does not negate the need for development approval of such earthworks.

6.3 Requirements

The following earthworks and lot filling requirements apply to all developments:

- All work shall be undertaken in accordance with AS 3798-2007
- Earthworks within an area of land liable to flooding must not adversely impact on the floodplain characteristics. Existing depressions shall not be filled either temporarily or permanently unless the consent of Council is given in writing and any relevant permits obtained
- All new urban subdivision allotments will be graded, cut or filled, such that a minimum grade of 1:100 is achieved along the low side of the allotment toward the drainage outlet
- The finished floor level of buildings will be a minimum of 500mm above the 100 year ARI flood level. Where a lot has the potential to have a future dwelling in an area below the 100 year ARI plus 500mm freeboard, a Restriction on Title specifying the required floor level will be created
- The finished surface of lot filling will be equal to or above the 100 year ARI flood level subject to the requirements of SELLS or responsible authority

Infrastructure Design Standard

- The extent and depth of all proposed lot filling shall be denoted on the construction plans. Where depths of fill on allotments exceeds 300mm, those areas are to be clearly differentiated from fill of depth less than 300mm
- Where the depth of fill is greater than 300mm lot filling must be compacted to the requirements of AS 1289.5.3.2, 2004 trimmed and shaped to match existing adjoining site levels, except in areas nominated for soft landscaping
- The requirements for the backfilling of drainage trenches are specified in Appendix C – Council standard drawings
- Design of any structure shall be provided to Council where earthworks abut structures
- Retaining walls will be provided when the maximum batter slopes are exceeded
- No water is to be directed to flow into adjoining properties
- Ideally earthworks should be designed to balance cut to fill. No fill should be imported onto any development site without prior approval by Council
- Dust, mud and debris shall be prevented from leaving any development site during and after construction.

6.3.1 Sediment and erosion control plans

Consideration should be given to recommendations within: RMS Road Design Guide Part 7 Drainage and; The Blue Book. Sediment and Erosion Control Plans should include, but not limited to, the following:

- Cut-off drains are to be installed to intercept surface water before it reaches the areas of disturbed earth
- Approved silt control measures are required at the entrance of all drains to ensure that all silt is retained within the site. Typical measures may include one or more of the following:
 - Settlement ponds
 - Fence filters
 - Gravel sausages made from a geo-textile sleeve for placement at kerbside drainage pits
 - Straw bales on open, cut-off or diversions drains
 - Temporary sumps in selected and approved drainage pits
 - Landscaping or the promotion of vegetation downstream of the works but still within the site.

Subdivision access points are to be kept to a minimum to minimize the number of areas required for stabilization, vehicle cleaning and areas of road to be targeted for cleaning in the event that mud is tracked onto the road.

Infrastructure Design Standard

7 Urban drainage

7.1 Objectives

The general objectives for urban stormwater drainage design are:

- To collect and control all stormwater generated by the development and entering into the development from its above catchment
- To ensure that inundation of private and public buildings does not occur in the specified major storm events
- To ensure that during major storm events, surface flow routes convey floodwaters below prescribed critical velocity/depth limits
- To provide convenience and safety for pedestrians and traffic in frequent stormwater flows by controlling those flows within prescribed limits
- Retain within each catchment as much incident rainfall and runoff as is possible and appropriate for the planned use and the characteristics of the catchment
- Provide an effective controlled outlet for all collected stormwater from development to Council's stormwater infrastructure, natural watercourse or approved outfall
- Achieve the above outcomes whilst protecting the existing environment (surface and subsurface water quality, groundwater infiltration characteristics, adjacent landowners and both up and downstream watercourse characteristics) from damage due to changed stormwater flows as a result of the development.

7.2 General

Developments are to provide a stormwater drainage system in accordance with the major/minor system concept set out in AR&R Vol. 1 Book VIII and in accordance with Section 1.3.3 – ARI Design Parameters. Property stormwater drainage is to be in accordance with *Council's Stormwater Disposal – Urban Land Policy* and Section 7.12

Where the proposed development replaces an existing development, any on-site drainage system is to be designed in such a way that the estimated peak flow rate from the site for a selection of design ARI is no greater than that of the pre-development site state. If this is not possible then the downstream system is to be upgraded.

All calculations are to be carried out in accordance with AR&R and be undertaken by a suitably qualified engineer or registered surveyor experienced in hydrologic and hydraulic design.

7.3 Floor levels

The floor level of development will be arbitrarily set at the height of the 1:100yr ARI flood level plus freeboard. Freeboard for residential development is 500mm. For industrial and commercial development freeboard is to be 300mm.

Infrastructure Design Standard

7.4 Hydrology

7.4.1 General

Stormwater drainage design shall include a drainage catchment plan detailing the total catchment and sub catchments, and a drainage computation sheet.

Sub catchments are to be taken into account when determining peak flow, careful checking of the partial area flows may be required to determine the largest peak flow which is to be used for the design of the stormwater system downstream of the development discharge/connection point.

Rational method calculations in determining peak flows are to be carried out in accordance with AR&R and the requirements of this IDS.

It may be appropriate in some circumstances to use a Unit-Hydrograph or Non-Linear Run-Off Routing model. Various drainage tools, programs and construction methods can be used by a suitably qualified engineer in the design of the stormwater system to achieve the objectives. Regardless of technique or method used, detailed documentation is to be submitted to Council for approval prior to final approval of design.

Refer to Appendix A - Stormwater Tables 26-29 for sample hydrological design sheet templates, calculations are to be in the form of Technical Note 6 of AR&R or as prescribed by an approved proprietary computer programs.

7.4.2 Catchment area

Consideration is to be given to the entire catchment, not just the area within the development. Peak flow calculations shall be on the full potential development of the catchment for both normal flow, overland flow paths due to pipe blockages, general flooding and high water levels.

Detailed survey of the proposed development and surrounds to sufficiently capture the total catchment is required to produce at least a 1m contour plan for the proposal. Where this is not possible due to physical constraints of the land, the use of 1:4000 Orthophotos, or Land and Property Information (LPI), Aerial Laser Survey are to be used in determining the catchment area and slope calculations.

Catchment area land-use will generally be based on current and/or future proposed zoning information, as determined by Council. Refer to Table 7 – Land use impervious percentage for percentage impervious values for the various land-uses within Shire.

Infrastructure Design Standard

Land use zone	Impervious %
Bush land	5
Land not contained in this table	10
Public reserves	25
Rural R5/E4	30
Residential	60
Medium density residential	80
Commercial/industrial	100
Road reserves	100

Table 7 – Land use impervious percentages

For areas of special use eg., schools, sporting developments, etc., an investigation is to be carried out to determine the likely percentage of impervious area and pervious areas to determine the appropriate coefficient of runoff.

7.4.3 Time of concentration

Where the flow path is through areas having different flow characteristics or includes property and roadway then the flow time of each portion of the flow path shall be calculated separately.

The maximum time of concentration in an urban area shall be 20 minutes unless sufficient evidence is provided to justify a greater time. The minimum time of concentration in an urban area shall be 5 minutes. Calculations comparing times obtained from the Kinematic flow vs Channel flow will be submitted for approval. Refer to Appendix A - Stormwater Figure 5 and 6.

7.4.4 Average Recurrence Interval (ARI) design parameters

To cater for major storms, floodways comprising the major drainage system are to be located over or near underground pipelines and be able to accommodate the 1:100yr ARI event.

The minor drainage system is to be designed to accommodate the flows from the following rainfall events:

Minor piped system	Design capacity - ARI
Residential	1:5yr
Commercial	1:20yr
Industrial	1:20yr
Parks or Recreational open space	1:1yr

Table 8 – Minor drainage system design

Where considered appropriate, detention basins and major structures may be required to be analysed for the Possible Maximum Precipitation event (PMP).

Infrastructure Design Standard

7.4.5 Rainfall Intensity Frequency Duration (IFD)

Council has identified four zones within the Eurobodalla Shire and compiled IFD data for each zone - refer to Appendix A – Stormwater Tables 20 to 23. Alternatively the following methods for IFD calculation are also acceptable:

- The relationship can be derived by the method as outlined in AR&R Vol.1 Book 2 or;
- IFD charts and tables can be calculated from the Bureau of Meteorology, via their website: <http://www.bom.gov.au/cgi-bin/hydro/has/CDIRSWebBasic> for any location providing the latitude and longitude of the location is known.

7.4.6 Coefficients of run-off

Run-off coefficients shall be derived from Figure 3 - Runoff coefficient chart - see Appendix A – Stormwater. Full details of coefficients used are to be documented and included in submission to Council. The run-off coefficient C_{10} is 0.6, refer to Table 9 for derived Frequency factors (FF_y).

ARI	Zone 1	Zone 2	Zone 3	Zone 4
1	0.37	0.37	0.37	0.37
2	0.47	0.47	0.47	0.47
5	0.54	0.54	0.54	0.54
10	0.60	0.60	0.60	0.60
20	0.66	0.66	0.66	0.66
50	0.69	0.70	0.70	0.67
100	0.74	0.75	0.75	0.71

Table 9 – Frequency factors (FF_y)

For specific sites Fraction Impervious (f) is to be used in determining the 10yr ARI runoff coefficient C_{10} from AR&R (Figure 1.13 Vol.1 Book VIII). The upper line for a $^{10}I_1$ of 70mm/hr shall be used.

For Rural areas the runoff coefficient C_y should be calculated using AR&R (Equation 1.13 Vol. Book VIII).

7.5 Hydraulic design

7.5.1 General

Designs are to be based on hydraulic grade line (HGL) analysis using appropriate pipe friction and drainage structure head loss coefficients.

The HGL due to partial full flows is to be ignored and assumed to match the obvert of the pipe, part full velocities must be checked.

For pipes designed to flow full and not under pressure, the pipe parameters are to be based on Colebrook – White formula, considering:

Infrastructure Design Standard

Pipe material	N	K
Spun precast concrete	0.013	0.6
Fibre reinforced concrete	0.011	0.3
UPVC	0.009	0.06

Table 10 - Pipe roughness values

In extreme circumstance Council may accept pressurised junction pits subject to submission of evidence that there are no alternative solutions.

7.5.2 Downstream water surface level

Downstream water surface level requirements are:

- Known hydraulic grade line level from downstream calculations including pit losses at the starting pit in the design event
- Where the downstream starting point is a pit and the HGL is unknown, a level of 0.15m below the invert of the pit inlet in the downstream pit is to be adopted
- Where the outlet is an open channel and the design storm is the minor event the top of the outlet pipe shall be the downstream control
- Where the outlet is an open channel, the design storm is the major event and downstream flood levels are not known, the top of the outlet pipe shall be the downstream control
- Where the outlet is an open channel, the design storm is the major event and downstream flood levels are known, the downstream control shall be the 1% AEP flood level
- Where the outlet is an open channel that is affected by tidal inundation, the design storm is the major event and downstream flood levels are known, the downstream control shall be the combined level of the 1% AEP flood level and the ocean inundation level.

7.5.3 Pipes

7.5.3.1 Size

For assets to be acquired by Council, the minimum pipe size is 375mm \emptyset , box culverts are to be a minimum 600mm wide x 300mm high.

For privately owned inter allotment drainage schemes within easements, a minimum pipe size of 150mm \emptyset PVC or 225mm \emptyset non PVC for the first connection. Once two or more dwellings are connected to the system, minimum pipe size is 225mm \emptyset regardless of pipe type.

7.5.3.2 Velocity

Minimum design velocity of flow in stormwater pipelines is 0.6m/s. The maximum design velocity is 6m/s.

Infrastructure Design Standard

7.5.3.3 Grade

Considering self-cleansing and construction tolerances, the minimum grade of a stormwater pipe is to be 1%. Flatter grades may be approved where it is demonstrated that the velocity is sufficient for self-cleansing.

7.5.3.4 Pipe cover/depth

Loads on buried pipelines include:

1. Fill over the pipe, which is a function of:
 - a. height of fill
 - b. type of fill material
 - c. installation conditions (e.g. trench or embankment).
2. Normal traffic loads
3. Construction traffic loads
4. Other or abnormal load conditions

The load bearing capacity of a pipeline is a function of:

1. pipe strength class
2. type of bedding and backfill material
3. pipe diameter.

The structural design of pipelines should be carried out in accordance with AS 3725 Loads on Buried Concrete Pipes, CPAA Pipe Class V2.0 Concrete Pipe Selection Software and the latest version of AustRoads Bridge Design Code

Refer Table 11 – Minimum pipe cover, for recommended minimum cover.

All pipes, box sections and access chambers in road reserves, whether under the road pavement or within the footpath area, and all pipes within Industrial and Commercial allotments, should be designed for a W7 wheel loading in accordance with AustRoads (2005). Note that the W7 loading should be modified for impact effects in accordance with the buried structures provisions and distributed in accordance with AustRoads (2005).

The minimum strength class for concrete drainage pipes should be Class 2.

Where aggressive ground conditions exist, or where the system might be exposed to salt water, it may be necessary to provide additional concrete cover to reinforcement or protective coating to exposed surfaces.

Refer to section 7.6.1 Pipe class

Infrastructure Design Standard

Location	Minimum Cover mm
Residential private property, and parks not subject to traffic	300
Private property and parks subject to occasional traffic	450
Footpaths	450
Road pavements and under kerb and channel	600

Table 11 – Minimum pipe cover

7.5.3.5 Pit losses

Pit losses to be calculated on the basis of:

$$K \times \frac{V_o^2}{2 \times g} \qquad V_o = \frac{Q_o}{A_o}$$

K is a head loss coefficient - refer Appendix A - Stormwater Figure 11 for various K values.

7.5.4 Gutter flow width

The acceptable gutter flow width in the 1:5yr ARI event is a maximum of 2m. Refer to Appendix A - Stormwater Figures 8-10 for gutter flow volumes for varying flow depths, cross falls, longitudinal grades and both standard and layback kerb.

7.6 Pipes

7.6.1 Pipe class

Required pipe classes will be determined in accordance with AS 3725-2007 and AS 4058-2007. Refer also to 7.5.3.4. Pipe cover/depth.

7.6.2 Pipe alignment at pits

Where practical, the pipes at junctions should be aligned such that the projected area of the upstream pipe is wholly contained within the downstream pipe else the pipe obverts are to match.

Side entry pits are to be spaced so that the pits are able to deliver the design flows into the pipes. Inlet capacity charts are to be consulted and provided to confirm the capacity in such circumstances.

Acute intersection angles between drainage lines at pits will not be permitted.

Infrastructure Design Standard

7.6.3 Maximum length

For the purpose of maintenance, the maximum spacing between pits and hence the maximum pipe length, is not to exceed 80m.

7.6.4 Pipe bedding and connection

Pipe bedding shall be determined in accordance with AS 3725-2007 and AS 2032-2006.

Pipe connections shall be spigot-socket Rubber Ring Jointed unless specific approval is obtained from Council's Engineering Development Services.

7.6.5 Curved pipelines

Curved pipelines will not be permitted unless there is sufficient evidence to determine that no other solution is possible/feasible. When required, curved pipelines are only permitted where they are of constant radius in the horizontal direction only and are in accordance with the manufacturer's specification.

7.6.6 Main drains

Drainage pipes of 750mm diameter or greater are to be designed as main drains. Large directional changes through standard pits will not be permitted. Consideration will be given to the use of special manholes and additional pits at all changes of direction.

Design criteria for main outfall drains shall be determined after discussion with the Coordinator of Council's Engineering Development Services.

7.6.7 Location

Drainage lines within road reserves shall be located behind the kerb line and parallel to the kerb. Drainage lines within easements shall be centrally located within the easement.

7.7 Pits

7.7.1 Benching

Pits are to be designed with benching to improve hydraulic efficiency, eliminate/reduce water ponding and clear debris. Generally the minimum drop through a pit is to be 20mm.

For drop through pits in excess of 2m, pits shall be designed in accordance with Austroads Road Design Guideline – Part 5 Drainage.

7.7.2 Pit design

For typical pit design and other design requirements, refer to Appendix C – Council standard drawings.

Infrastructure Design Standard

7.7.3 Location

Inlet pits shall be spaced so that gutter flow width is limited in accordance with this IDS - refer to Section 7.5.4 – Gutter flow width. Pits are to be provided at a maximum spacing of 80m.

Pits are to be located at changes in: direction; grade; level or class of pipe.

Pits are also required at the following critical locations: junctions; upstream of pedestrian points and sag points in overland flowpaths.

Channel flow approaching an intersection is to be collected before the tangent point of the kerb return except where it can be demonstrated that adequate capacity is available in the kerb and gutter to carry water around the return.

Side entry pits are to be kept clear of radials, kerb crossings and driveways (minimum 3m). Double side entry pits will be used where approach grades to intersections are in excess of 6% and at low points in roads, unless it can be demonstrated that a single side entry pit provides sufficient inlet capacity for the pipes to operate at their required capacity.

Preference will be given to the location of drainage pits at the upstream side of allotments.

7.7.4 Prefabricated pits

The use of prefabricated pits/components requires submission to Council of appropriate technical detail factsheets including: Materials; Specifications; Dimensions; Product Data Sheet and any advantages/disadvantages where appropriate.

Approval of the use of prefabricated pits is required.

7.7.5 In-situ pits

Stormwater pits cast in-situ are to conform to Appendix C – Council standard drawings and this IDS.

7.7.6 Capacity

Pit capacities shall be in accordance with Austroads Road Design Guidelines Part 6: Drainage.

7.7.7 Covers

Pit covers will have a clear opening of sufficient dimension and orientation to comply with WH&S and confined space entry requirements.

Heavy duty lids or lock-down lids may be required in high risk areas such as public open spaces, recreation reserves, school areas, etc., else they are to be installed with class rating in accordance with potential traffic loadings.

Trafficable gatic or approved equivalent, load bearing covers are to be provided on all side entry pits located in exposed kerb areas. Load bearing covers are to be provided on all pits in industrial and commercial development areas.

Infrastructure Design Standard

7.7.8 Litter collection

Litter collection pits are to be provided at the end of any drainage line that discharges to a watercourse and/or drainage basin. The pit must be located such that comfortable access by maintenance vehicles is achieved.

Default design cleaning period is to be taken as six months.

7.8 Subsoil drainage

Subsoil drainage of a minimum 3m length will be provided in the bottom of the stormwater pipe trench immediately upstream from each pit or headwall.

Subsoil drainage lines are to be provided behind the kerb, for the length of the kerb, on the high side of the road structure.

The downstream end of the subsoil drain shall discharge through the wall of the pit or headwall. Flushing points are to be installed at the remote end from the pit where a subsoil drain is provided behind the kerb and gutter.

The subsoil drain shall consist of 100mm diameter agricultural pipes, butt joints wrapped with hessian or slotted PVC pipe, geotextile sock is to be provided when requested by Council. Subsoil drains are to be laid at the same longitudinal grade as either the stormwater pipe or kerb and gutter at a minimum of 1%.

Full details of all subsoil drainage proposed by the development is to be provided for approval prior to issue of a construction certificate. Refer to Appendix C – Council standard drawings

7.9 Drainage swales/table drains

Table drains and are to be designed in accordance with Austroads Guide to Road Design Part 5: Drainage Design.

Rock lined drains will not be permitted in Eurobodalla Shire.

Established grass lined channels should have a limiting velocity of 2.0m/s, channel stabilisation is required for velocities in excess of 1.5m/s.

Refer to Appendix C - Council standard drawings.

7.10 Stormwater discharge

Stormwater discharge shall be located to avoid recharging groundwater and creating/worsening salinity degradation of adjacent land. Stormwater discharge shall be located to avoid areas with high groundwater tables, groundwater discharge areas or salt affected land.

Outfall structures or discharge points for floodways at receiving waters shall be designed in accordance with the requirements of the appropriate authorities for the relevant land and receiving waters, including consideration for salinity and turbidity levels of discharge to natural watercourses.

Infrastructure Design Standard

7.11 Scour protection

Scour protection is to be provided at the point of discharge from all stormwater drainage lines. Refer to Table 13 – Gabion sizing to assist in determining required scour protection for discharge velocities less than 5.0m/s. The length of scour protection to be provided is to be a minimum four times the width of the discharge pipe or culvert.

Velocity m/s	Rock diameter mm	Gabion thickness mm
Up to 3.0	70-100	170
3.0 – 4.0	70-100	250
4.0 – 5.0	100-150	300

Table 12 - Gabion sizing

For discharge velocities in excess of 5.0m/s the use of more specialised energy dissipation is required. Design of these structures is to be undertaken by a suitably qualified consultant.

Kerb and gutter is to be extended to a drainage pit or natural point of outlet. Where velocity is greater than 1.8m/s or where the kerb and gutter discharge is likely to cause scour, protection is to be provided to dissipate the flow and prevent scour.

Scour protection is to be provided at the inlet to drainage structures from open channel drains where inlet velocities exceed 1.8m/s. The length of protection to be provided as a minimum being the length of the wing walls, up to a length four times the pipe/culvert width, depending on soil type.

7.12 Property drainage

7.12.1 General

All development is required to provide a stormwater drainage system, comprising a roof system and a surface drainage system.

The design and installation of stormwater drainage systems shall be in accordance with the relevant Australian Standards, primarily AS/NZS3500.3, except where varied by this IDS.

7.12.2 Inter allotment drainage

Inter allotment drainage provides an effective drainage solution where roof and surface water cannot be discharged directly into Council's street drainage system.

Inter allotment drainage is to comprise of a minimum 150mm diameter PVC Class SH single pipeline. Where two or more lots are serviced by the drainage system a minimum 225mm pipe is required.

The drainage system is to be designed for a 1:20 year ARI, with the pipeline located generally parallel and within 1m of the rear, side or front boundary within the allotment to be serviced. An easement is to be created over all inter allotment drainage structures.

Inter allotment drainage is to be located wholly in the private property with relevant easement and only on Council land within the direct vicinity of the point of termination.

Infrastructure Design Standard

7.12.3 Stormwater absorption

7.12.3.1 Permitted Use

An absorption disposal system is the preferred method of disposing stormwater from a single dwelling **only** where site gradients do not allow for street gutter disposal or disposal via an inter allotment drainage pipeline.

Absorption and transpiration disposal systems will not be permitted for new developments, with the exception of single residential dwellings in older subdivisions.

Note: Absorption disposal systems will not to be used as storage facilities to control peak discharge of stormwater from development sites.

Also, absorption disposal systems should not be used for sites having steep gradients, low hydraulic soil conductivity or slope instability unless supported by further detailed engineering advice. Absorption systems on unstable land must take into consideration the recommendations of a geotechnical report.

7.12.3.2 Trench Location and Layout

The location of an absorption or transpiration disposal system must be parallel and horizontal to the contours of the site, and situated a minimum of 3m from property boundaries (1.0m setback from front boundary), 3m minimum distance from all buildings and 1.5m minimum from vehicular pavement areas. A zero setback from the downslope property boundary may be considered where the property is public reserve. Refer to Appendix C – Council standard drawings.

The design of the chosen system, including all calculations and supporting documentation shall be submitted with the DA for the proposed development.

Stormwater absorption trenches are best suited to areas identified as Class A or S soils. Due to the inability of other soil types to suitably drain and the loss of bearing capacity in other soil types due to waterlogging, Council recommends alternative drainage methods be employed. If no alternative can be found absorption trench location is to be offset 5m from buildings for Class M (2m for Class A and 3m for Class S soils as per Appendix C – Council standard drawings)

7.12.3.3 Required Capacity

Stormwater absorption systems are to be designed to ensure that stormwater flows to adjoining properties do not exceed predevelopment conditions for up to the 1:20 year ARI event. For single lot development stormwater absorption design will conform to the following volume requirements in Table 14 – Absorption trench Capacities

Impervious area IA	Absorption capacity
IA ≤ 75 m ²	1 m ³ /25 m ² IA
IA > 75 m ²	Analysis required by consultant

Table 13 - Absorption trench capacities

Infrastructure Design Standard

7.12.4 Charged Systems

A charged stormwater system will only be permitted where the roof gutter or tank outlet, whichever is lower, is no less than 1.5m above the corresponding kerb. Where height above the kerb is between 0.5m and 1.5m, approval will be dependent on provision of analysis of head losses verifying the functionality of the system.

Approved alternative disposal methods need to be provided to drain driveway and other hardstand areas.

Charged stormwater discharge systems will not be a permitted method of stormwater management for development larger than one single dwelling.

The system is to be completely sealed with an inspection/cleaning eye and bleeding point provided at the lowest point.

Pipes used in sealed section of the line are to be of sewer grade quality.

7.12.5 Connection to Council infrastructure

No property drainage will be permitted to discharge into Council's kerb and gutter infrastructure for greenfield development.

For single lot infill development/redevelopment, where a Council pit is within 10m of a property boundary (on the same side of a road) the development will be required to connect directly to the pit, as per Appendix C – Council standard drawings, unless it can be demonstrated that the number and location of street trees or adjoining property's sealed surface driveway make it impractical.

For infill development of two or more lots or dual occupancy the above distance, for mandatory connection to Council's pit, will increase from 10 to 50m.

For development connecting directly to Council's stormwater pipe the connection is to be made in accordance with Appendix C – Council standard drawings. Direct connection to Council's pipe will be limited to pipes up to a diameter of 225mm. For connections of pipes larger than 225mm diameter a 'blind' pit will be required, refer to Appendix C - Council standard drawings.

7.13 Major system structures

The major system, which includes escape routes or overland flow routes for flows in excess of piped system capacity must be designed and/or checked for the 100 year ARI event.

7.14 Pump stations

Stormwater pump out stations are not permitted within the Shire.

7.15 Easements

Easements are to be created over all drainage structures passing through land not owned by Council and reflected on the subdivision plan/plan of survey and Section 88B Instrument.

Infrastructure Design Standard

All pipes are to be centrally located within their easement, with the easement to be created to burden the fewest number of allotments as practical.

Easements created for the benefit of Council are to be a minimum 3m wide. For pipes greater than 600mm diameter the easement width is to be the diameter of the pipe plus 3m.

Easements not benefiting Council eg, inter allotment drainage, the minimum easement width is to be 1m, for pipe sizes over 300mm diameter easement width is to be 1m plus pipe diameter allowing adequate access for private maintenance.

7.16 Submission requirements

Plans to be submitted in accordance with Appendix B – Information to be shown on plans.

All calculations are to be submitted with detailed design for approval.

Where an easement is proposed to service an allotment, supporting documentation signed by all the owners of all burdened lots over which the easement will pass granting their permission to create the easement, is to be submitted with the application for approval to demonstrate to Council that a suitable easement can be created.

7.17 Additional reference material

Water Sensitive Urban Design Guidelines – South Eastern Councils: Melbourne Water, April 2013

Urban Stormwater Best Practice Environmental Management Guidelines: CSIRO 1999

AS 3500.3 – Stormwater Drainage.

Infrastructure Design Standard

8 Rural drainage

8.1 Objectives

The general objectives of rural drainage are:

- To collect and control all stormwater generated within the development or subdivision to ensure that it is discharged from the site in a way that does not detrimentally impact on any upstream or downstream property
- That any developments or subdivisions that have the potential to increase the rate and quantity of stormwater runoff shall be detained to rural runoff rates where applicable
- To provide an effective outlet to an approved outfall
- To ensure that culverts and waterways are designed so that any overtopping of any roadways will be such that it allows for the safe passage of vehicles
- That stormwater flows are generally restricted to natural drainage lines and drainage catchment boundaries are not crossed
- Comply with the objectives and requirements of any relevant Floodplain Authority
- That there be no detrimental effect on:
 - The environment generally
 - Surface and subsurface water quality
 - Groundwater infiltration characteristics
 - Adjoining landowners and other landowners in the vicinity of the drainage outlet
 - Watercourses either upstream or downstream of the development or subdivision.

8.2 General

Drainage design will give consideration to the entire drainage catchment not just the area included in any development or subdivision.

Designers are to take into account upstream developments, overland flow paths, natural drainage lines, possible removal of unnatural drainage obstructions, and depth of flooding that may occur on roads and private property and other factors which may impact on or be impacted by, the design of any rural drainage system.

Council is considered a landowner/manager of local roads and therefore the construction and maintenance of local roads must not cause water to flow from the road reserve in an unreasonable manner or prevent the natural flow of water across or along a local road reserve from occurring in a reasonable manner.

8.3 Requirements

Stormwater runoff estimation for rural catchments (undeveloped areas) will be based upon hydrological methods set out in AR&R, unless otherwise specified within this IDS.

A recognised flow estimation method (runoff routing computer models) in addition to the Rational Method will be used for comparative purposes for rural farming catchments or sub-catchments greater than 50 ha.

Infrastructure Design Standard

8.4 Minor drainage

In addition to relevant sections of Section 12.3 – Requirements, the following applies to the minor drainage systems in E4 and R5 zoned precincts areas:

- The minimum pipe size for road cross-culverts shall be 450mm so that maintenance of the culvert is facilitated
- The minimum slope of earth drains shall be 1:100
- The minimum bed width of the drain shall be 1m unless otherwise approved
- The desirable maximum batter slope of earth drains within the Clear Zone will be 1:6, with the absolute maximum batter slope of 1:4. Where the drain is located outside the Clear Zone the maximum batter slope will be 1:1.5 or the stable slope
- The discharge of any roadside table drain into a drainage authority drain requires that authority's approval and the structure will be designed in accordance with their requirements
- Property connections in E4 and R5 zoned precincts will discharge through the side of the headwall and not directly into the table drain.

Culverts will be sized with the following capacities refer to Table 14 – Rural drainage culvert ARI capacities:

Drainage system	Capacity
Rural road culverts	1:20yr ARI
Major rural culverts	1:100yr ARI

Table 14 – Rural drainage culvert ARI capacities

The design should consider how to provide for flows exceeding the capacity of the pipe so as to avoid flooding in these events eg., floodway to be incorporated with culvert installation.

8.5 Major drainage

The major drainage system will collect major storm runoff from a catchment, in excess of the capacity of the minor drainage system and convey this runoff to the receiving waters with minimal nuisance, danger or damage. The major drainage system will be designed so that its function ensures a reasonable level of vehicular traffic safety and accessibility, limits flooding of private and public property, and minimises pollutants inflows to receiving waters.

Design of major drainage systems shall consider use of wetlands, gross pollutant traps and sediment interception ponds.

Council will consider major floodways through easements in private land in rural living developments where alternatives are not practicable.

Minimum requirements of the major drainage system in rural areas are:

Infrastructure Design Standard

- Design of major drainage systems shall be based on the critical 100 year ARI storm with some consideration given to the impact of a rarer storm event. The critical storm shall be determined by routing storms of varying duration until peak flows are identified.
- Hydraulic Grade Line analysis shall be used for design of floodways, low flow pipes and detention basins. The width of major floodways shall be governed by the greater of the hydraulic requirements or the width for suitable maintenance, including mowing of grassed trapezoidal drains.
- Depth of overland flows shall be controlled by freeboard to properties or upper limits of surface flow depth/velocity criteria for public safety as detailed in RMS Road Design Guidelines Part 7
- Road drainage in low density areas may be directed into easements drains
- Minimum width of easements for open drains in rural areas will be defined by 3m from both cut hinge points as per Figure 1 Minimum width of easement below.

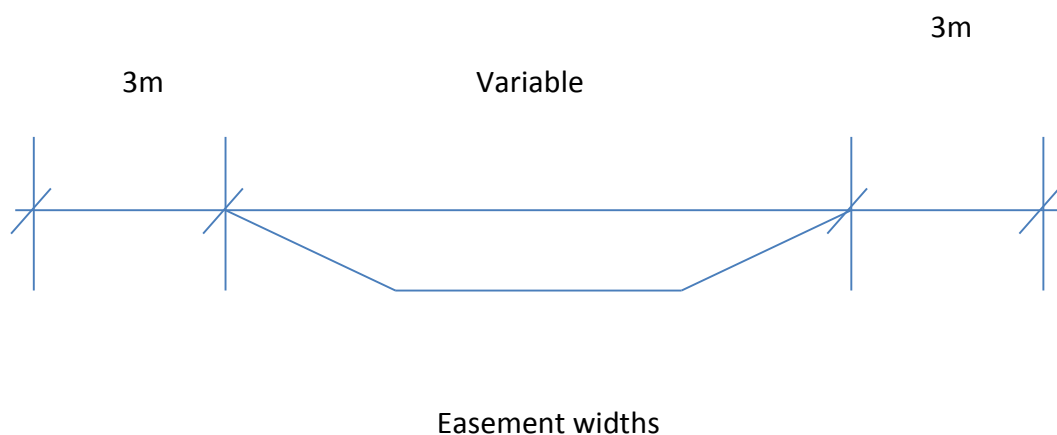

Figure 1 – Rural major open drains minimum width of easements

Infrastructure Design Standard

9 Large scale stormwater detention

9.1 Objectives

- To protect property and infrastructure from flooding occurring from a nominated rainfall event by the provision of detention basins
- To limit, as much as possible, the number of detention basins servicing an area in order to reduce Council's future maintenance expenditure
- Detention basins, if designed as standalone basins, shall be designed to drain completely and be designed so that the area can be used for passive or active recreation or other uses such as car parks as determined by Council
- To incorporate stormwater treatment and litter traps into the detention basin design where practical and required by Council
- To protect Council's existing stormwater drainage assets from overloading as a result of new developments which increase the amount of stormwater runoff being generated from a particular property. This can be achieved through on-site detention or increasing outfall drainage capacity.
- To protect the public from risk of injury or death
- To standardise the type of outfalls associated with detention basins
- To improve the quality of stormwater runoff being discharged from a particular development using WSUD principles
- Detention basins shall be designed so as to be aesthetically pleasing and to have regard to the area that they will be located in. They should not have an adverse amenity impact on the surrounding areas.

9.2 The use of drainage basins for public open space purposes

The provision of public open space should include:

- Suitably dimensioned and designed to provide for the intended use, buffer areas around passive open space
- Appropriate for the intended use in terms of quality and orientation
- Located on flat land which can be cost effectively graded, where appropriate
- Located with access to, or making provision for, a recycled or sustainable water supply, where appropriate
- Adjoin schools and other community facilities where practical
- Incorporate the construction of shared walkways
- Not be inundated by a 1:100 year ARI event. Council may determine, in its sole discretion agree to a lesser standard, but in no case be inundated by a 1:5 year ARI event or more regular event.

Infrastructure Design Standard

9.3 General

Detailed design and documentation of drainage basins and/or similar detention facilities are to be prepared by a suitably qualified civil engineer.

Design shall consider the requirements for a suitable stormwater detention system and demonstrate that a system can be integrated into the drainage system. The detention basin location shall be in accordance with any Council Strategy/Stormwater Management Plan.

Any design will be consistent with the requirements of Council and SELLS eg., detention basins with outfall to relevant authority drains.

Land that has been identified for stormwater detention basins to be maintained by Council, whether existing or proposed, must be shown on a plan of subdivision as a drainage reserve and is vested in Council.

In circumstances where detention basins are not to be maintained by Council and are located within land that is common property, Council is unlikely to be a member of the body corporate. In this instance Section 88B Instrument will be placed on each benefiting allotment to ensure that drainage of Council's roads or reserves is not compromised by any act, or failure to act, by the body corporate.

When a detention basin is required for any development, the basin and any overland flow paths will be constructed as part of stage one works. Where it can be demonstrated to Council that a detention basin is not required as part of the first stage works, plans, computations, and relevant approvals must be provided to confirm the alternate method of outfall and/or storage capacity provisions.

9.4 Larger detention basin design requirements

9.4.1 Location and siting

Detention basins will not be sited in areas zoned Urban Flood Zone or land affected by Flood Overlay. Detention basins sites may be considered within an area affected by a Land Subject to Inundation Overlay.

Works must be carried out at the location of any incoming flood paths, which will minimise erosion and maintenance following any overland flows.

Siting of detention basins shall have regard to:

- The physical dimensions required for storage volume including the flattest possible batters, access to the basin bed, and maintenance of batters and edges.
- Pre-development catchments
- Existing developed catchments
- Existing drainage including piped, swale drains, or flow paths
- Existing and proposed drainage easements
- Ground water depth and seasonal fluctuations
- Subsoil characteristics
- Location and point of discharge

Infrastructure Design Standard

- Soil type and seepage rate
- Land uses and zoning
- Effect of overland flows external to the catchment
- Potential risk or effect on people, fauna and flora
- Amenity of the area
- Benefiting landholder issues
- Maintenance issues and all weather access
- Water quality
- Whether or not the detention basin is proposed to be used or included in the calculation for public open space
- The location of overland flows into the basin and the treatment(s) to minimise erosion
- Inlet velocity and the need to install energy dissipation structures
- 1% flood level or highest recorded flood level information.

9.4.2 Design criteria

Detention basins shall be designed for the critical 100 year ARI storm. Detention basins with downstream established areas, and no clear and safe overland flow paths, shall be designed for the critical 100 year ARI storm with consideration given to a rarer Probable Maximum Flood (PMF).

Where it can be demonstrated that a 1:100 year storm event will be irrelevant due to cross catchment storm flows and overland flows swamping the catchment and/or the basin, a lesser storm event and corresponding storage capacity may be considered by Council.

Minimum freeboard will be 300mm for earth structures and 200mm for hard structures. Council will require a minimum freeboard to top basin water level (following a 1:100 year peak storm, no outfall condition) equal to lowest kerb invert level in the catchment area. This is subject to:

- The top water level in the detention basin resulting from the minor drainage storm event and will be no higher than the invert of the lowest inlet pipe to the basin
- The overland flow path for a major storm shall be designed such that the minor system contribution to flow is ignored eg., inlet pipe is blocked
- For storage calculations, the volume of storage in pits and pipes in the minor system is ignored.

9.4.3 Inlet structures

Any inlet to a basin must have an approved inlet drainage structure and may have a low-flow pipe.

Any inlet pipe to a basin must be fitted with a headwall and an approved structure that will allow debris escape and impede the entry of children.

All inlet headwalls will be fitted with an approved post and rail barrier to prevent falls and to identify the location of headwalls and wingwalls.

Infrastructure Design Standard

9.4.4 Low flow pipes

Detention basins shall incorporate a low flow pipe system having a minimum pipe size of 300mm diameter. The low flow pipe system shall be designed to match the outflow capacity where this is less than a 1:5 year storm event.

9.4.5 Overflow systems

A suitable overflow system must be provided to cater for rarer storm events than what the system has been designed for and to provide for a blockage in the system. All overflows are to be directed away from buildings, adjoining properties and associated Infrastructure. The overflow system shall be designed to cater with a 1:100 year storm event.

The depth of overland flow shall be designed so that it is no higher than 500mm below the lowest floor level of any dwelling impacted by the overflow.

9.4.6 Depth of detention basins

All excavations are limited to 0.5m above the water table.

Detention basins may require an impervious lining or other treatment to the approval of Council to prevent the ingress of groundwater.

Groundwater may be able to be extracted and used, subject to the relevant authority's requirements.

Any structure that penetrates the groundwater zone such as footings and drainage shall be appropriately treated to prevent possible damage caused by contact with ground water.

The depth of all other detention basins for which the public have access will be determined having regard to the safety of persons who may fall into or enter into the basin during times of operation. To allow for this contingency, basins will be designed with inside batters having a maximum slope of 1:8. This slope will determine the maximum depth of many detention basins.

9.4.7 Batter slopes in earthen basins

Where access is to be provided the desirable maximum batters for detention basins is 1:8 for both cut and fill situations. The absolute maximum batters shall not exceed 1:5 both cut and fill situations. The use of the absolute maximum batter slopes will only be permitted after approval in writing has been obtained from Council.

The batter slopes for detention basins which do not require access or where they are fenced eg., industrial sites the batter slope shall be determined having regard to:

- Soil type
- Erosion
- Maintenance
- Safety and minimisation of risk
- Desirable minimum crossfall for floor to be 1:400 graded to the outlet point of the basin.

Infrastructure Design Standard

9.4.8 Access requirements

All weather access is to be provided to the detention basin and any associated structures to enable maintenance to be carried out. The access should be provided in such a manner that there is no need for a vehicle to reverse at any time. The access should be provided so that maintenance of any portion of the basin and its associated works can be safely carried out therefore a 5m width reserve shall be required around the perimeter of any detention basin, unless written approval is given otherwise.

9.4.9 Risk analysis

A risk assessment report is to be prepared by design engineer for all drainage structures, including basins and associated structures. The risk assessment should be undertaken in accordance with the principles of AS/NZS 31000, 2009.

The design engineer shall be responsible for deciding on the action required in response to the risk assessment report and its recommendations, however consultation with Council is encouraged if recommendations are complicated, require community involvement, or have significant ongoing maintenance issues.

A copy of the risk assessment report, with recommendations and associated works, shall be provided to Council with the detailed design documentation.

9.4.10 Fencing and security

Detention basins which are not accessible to the public shall generally be fenced off and made safe against casual entrance, unless approved otherwise. Where batters are steeper than the current standard for publicly accessible areas, and are not proposed to fence off the basin, then a risk assessment will be required to be submitted to Council for their consideration.

Where the risk assessment determines that the above ground storage system or detention basin should be fenced due to public risk, the fence shall be 1.8m high chainmesh fence and shall be installed for the entire perimeter. Suitable access via lockable gates shall be provided for maintenance purposes.

9.4.11 Landscaping

A fully detailed landscape plan for all detention basins shall be submitted to Council for approval.

9.4.12 Maintenance

In general light duty grates and covers for pits will be sufficient however where the pit is located in the wheel path of vehicles a heavy duty grate or cover shall be provided.

Access covers and grates are to be designed such as to provide a standard lifting system approved by Council.

Infrastructure Design Standard

Any large pipe inlets into the basin shall be grated in a satisfactory manner to prevent entry to the stormwater drain. The grates shall be designed so that they can easily be maintained and so that they will not cause blockages during storm events.

Pits, pipes, screens, etc., that require regular cleaning and maintenance shall be readily accessible with all openings of suitable geometry to allow for cleaning and removal of debris and silt accumulations.

Infrastructure Design Standard

10 Small detention systems

10.1 Objectives

The objectives of small on-site detention systems are:

- The capacity of existing drainage infrastructure shall not be exceeded as a result of developments which increase the volume and rate of stormwater runoff beyond the capacities originally designed for
- The likely cumulative impact of similar developments shall not adversely impact on the capacity of the existing drainage system
- To reduce runoff and peak flows from urban and rural developments into receiving waters
- To minimise drainage infrastructure costs of development due to reduced runoff and peak flows
- That on-site detention systems are able to be effectively maintained by landowners and provide a cost effective method of meeting the other objectives of this section
- Provide a simplified method for designers, builders and owners to determine Council's requirements for on-site detention in relation to volume of detention and permissible rate of discharge to Council's drainage system.

10.2 General

The following types of development typically require on-site detention:

- Multi-unit development in new residential areas where this has not been incorporated into the design of the drainage system for these areas
- Multi-unit development in older residential estates where the drainage system at the time of design and construction provided a capacity less than the current standard of 1:5 year recurrence interval, and was typically about a 1:1 year recurrence interval
- Industrial development where the pipes have been designed for less than the current design recurrence interval of 1:20 years
- Commercial development where the pipes have been designed for less than the current design recurrence interval of 1:20 years
- Development in E4 Environmental Living and R5 Large Lot Residential zoned precincts.

Infrastructure Design Standard

10.3 Requirements

10.3.1 General

Where on-site detention is required in order to discharge into Council's existing drainage system the developer shall provide computations to Council's satisfaction which show the calculations used to determine the volume of on-site detention required and the permissible rate of discharge to ensure that Council's existing drainage system is not adversely impacted by the development.

The permitted discharge from the site must be calculated and based on the receiving pipes design capacity and not upon the predevelopment rate eg., if the pipe that is receiving the discharge has been designed for a 1:1 year recurrence interval for a time of concentration of 20 minutes then this is what determines the intensity and the resulting permissible site discharge from the property.

Predevelopment rate is not used because this does nothing to relieve situations where the predevelopment rate is greater than the receiving pipes capacity to take that flow.

10.3.2 Specific design requirements

No part of the pipe system within a detention system, which conveys water shall be less than 90mm in diameter unless it is part of an approved manufactured system or it is part of the restriction to achieve the design flow rate eg, orifice plates or pipes discharging from an above ground tank.

A suitable overflow system must be provided to cater for rarer storm events than what the system has been designed for and to provide for a blockage in the system. All overflows are to be directed away from buildings, adjoining properties and associated infrastructure. The overflow system shall be designed to cater with a 1:100 year storm event.

The depth of overland flow shall be designed so that it is no higher than 500mm below the lowest floor level of any dwelling impacted by the overflow.

The system shall be designed using the following:

- Recurrence interval 5 years
- Coefficients of runoff (C)
 - Existing residential 0.50
 - Impervious areas 0.90
 - Pervious areas 0.15.

The following minimum information is to be supplied to Council for approval:

- Plan showing invert levels of all pipes 100mm or over
- Plan showing the designed finished surface level of all driveways, car parking areas, landscaping areas and lawns
- Plan showing floor levels of all buildings whether existing or proposed. Note all floor levels must be at least 500mm above the top water level of the detention device when it is full to its design capacity
- Cross section of the detention device

Infrastructure Design Standard

- Existing surface levels at intervals not exceeding 10m, note this is also required for adjoining properties
- Plan showing location of detention device, position of all pipes and pits, pervious and impervious areas, buildings, driveways, etc.,
- Driveways, where these are used for on-site detention, shall be bounded by kerbs of not less than 100mm in width, and shall be cast integrally with the main slab unless otherwise approved
- One copy of drainage computations
- One copy of structural computations where underground storage tanks are to be used for stormwater detention
- Three copies of final engineering plans for final approval.

10.3.2.1 Time of concentration

The time of concentration for the whole catchment and from the top end of the catchment downstream to the site is to be advised to Council in each case.

10.3.2.2 Approved types of on-site detention

There are various systems that have been approved for use as follows:

- The use of above ground water storage tanks
- The use of driveways/carparks to store the stormwater and then discharge through a multi-cell unit or orifice plate to retard the flow to the design flow specified
- Underground tanks of various configurations discharging at gravity through an orifice plate or multi-cell unit
- Excavated earthen storages with gravity outfalls in low density residential developments.

Infrastructure Design Standard

11 Stormwater treatment

11.1 Objectives

- To ensure that all stormwater discharged to natural watercourses and other drainage authority's drains meet the requirements of SELLS and the water quality performance objectives for individual drainage catchments are met
- To ensure all designs incorporate consistent best practice WSUD measures and principles
- To ensure treatment methods and associated structures are cost effective from a maintenance and operational perspective and that the risk to the public is minimised as far as practicable
- Protect and enhance natural water systems within urban environments
- Integrate stormwater treatment into the landscape, maximizing the visual and recreational amenity of developments
- Improve the quality of water draining from urban developments into receiving environments.

11.2 General

All developers must make provision for the improvement of water quality leaving the development site. Generally treatment shall comprise works at a location near the discharge point to receiving waters. These works shall be maintained, to the satisfaction of the Council, by the developer until the end of the maintenance period.

All urban developments shall meet the requirements of the Urban Stormwater Best Practice Environmental Management Guidelines 1999, Water Sensitive Urban Design Guidelines January 2009 prepared by Melbourne Water and Water Sensitive Urban Design prepared by Landcom.

The following stormwater treatment methods may be considered, subject to Council approval, to enable compliance with the codes and guidelines.

- Bioretention swales
- Bioretention basins
- Vegetated swales
- Underground sand filters
- Sedimentation basins
- Constructed wetlands
- Pond system with edge vegetation
- Water tanks
- Gross pollutant traps
- Litter traps.

Infrastructure Design Standard

Further to this, Council may require setting aside areas of land and construction of works within a subdivision and/or DA for the specific purpose of stormwater treatment to ensure appropriate discharge water quality.

An appropriately qualified and experienced environmental specialist may need to be engaged by the developer or the developer's representative to determine the requirements for the project.

11.3 Requirements

11.3.1 General Requirements

The following are general requirements for the provision of stormwater treatment:

- Developments must comply with principles and recommendations of Water Sensitive Urban Design Guidelines 2009, Urban Stormwater – Best Practice Environmental Management Guidelines and Council's Stormwater Management Plans to achieve the following water quality standards:
 - 80% retention of the typical urban annual load for Total Suspended Solids (TSS)
 - 45% retention of the typical urban annual load for Total Phosphorus (TP)
 - 45% retention of the typical urban annual load for Total Nitrogen (TN)
 - 70% retention of the typical urban annual load for gross pollutants (litter).
- Discharges for an average 1.5 year ARI are to be maintained at pre-development levels for stormwater treatments
- Treatment types shall be determined by the developer, subject to approval by Council after satisfying Council standards for maintenance, ongoing costs and stormwater quality standards achieved
- Design of industrial estates will be required to contribute to treatment off site if Council has whole of catchment treatment. Designers may also need pre-treatment within the proposed development in accordance with the requirements of Council's Stormwater Management Plan. Where whole of catchment treatment is not available, design will be required to provide separate treatment for the development
- Staging and design of developments is to be considered. Only construct treatments when there are sufficient houses built to generate sufficient runoff to keep plants alive. Council to bond the value of the plantings in preference to have planting at inappropriate time
- No manual handling is to be involved for the cleaning and maintenance of structures and equipment associated with the treatment of stormwater. Routine maintenance must be carried out without need for access of confined spaces
- Developers shall undertake a risk assessment for all treatment sites. The assessment shall include fencing, grates across drains, wetlands, detention basins, pumping stations, and other associated structures.

Infrastructure Design Standard

11.3.2 Gross pollutant traps

The design requirements for gross pollutant traps are:

- For sizing gross pollutant trap (GPT) units the following design flows, depending upon the degree of hydraulic effectiveness required, are used:
 - $Q(3 \text{ months}) = 0.2 \times Q5 \text{ year design flow}$ typically has a hydraulic effectiveness of greater than 97%
 - $Q(6 \text{ months}) = 0.33 \times Q5 \text{ year design flow}$ typically has a hydraulic effectiveness of greater than 98.5%
 - $Q(1 \text{ year}) = 0.5 \times Q5 \text{ year design flow}$ typically has a hydraulic effectiveness of greater than 99%
- Selecting a design flow rate is a trade-off between the cost and space requirements of the device (a higher design flow will usually require a larger facility with additional costs) and the volume of water that could potentially bypass the measure and avoid treatment. GPT will generally be designed to treat a minimum design flow of a 1:3 month ARI, the developer will provide all weather access to all treatment sites to the satisfaction of Council and should allow for crane access to GPT. Access shall not require maintenance vehicles to reverse in new developments or public areas.
- Discharge water quality standards shall meet the requirements of Council refer 11.3.1 General requirements
- For design purposes the cleaning frequency of a GPT is every six months.

11.3.3 Bioretention swales

Bioretention swale design requirements are:

- Typically bioretention swales are best suited to slopes of 1 to 4% or where velocities during major storm events do not exceed 2m/s. Where excessive grades are identified as a constraint, check dams may be required to reduce velocities.
- Water ponding at entry points to the swale should not occur for longer than 1 hour after the cessation of rainfall
- For maintenance requirements, grass swales requiring mowing must not have side slopes exceeding 1:4
- Should be in accordance with the guidelines set out in Chapter 5 (Clause 5.3) of the Water Sensitive Urban Design Engineering Procedures: Stormwater Manual (Melbourne Water, 2005).

Infrastructure Design Standard

11.3.4 Bioretention basins and rain gardens

The design requirements for bioretention basins and rain gardens are:

- Water ponding at entry points to the swale should not occur for longer than 1 hour after the cessation of rainfall
- Should be in accordance with the guidelines set out in Chapter 6 (Clause 6.3) of the Water Sensitive Urban Design Engineering Procedures: Stormwater Manual (Melbourne Water, 2005)
- The use of bioretention basins and rain gardens are not permitted in unsuitable locations for access, permanent subsurface flow conditions, etc.

11.3.5 Vegetated swales/grass swales/buffer strips

The design requirements for vegetated swales/buffer strips are:

- The longitudinal slope of a swale is the most important consideration. Swales are most efficient with slopes of 1% to 4%. Lower than this, swales become waterlogged and/or have stagnant pooling, while steeper slopes may have high velocities with potential erosion and vegetation damage risks. Check banks (small porous walls) may be constructed to distribute flows evenly across the swale if they are identified as the most suitable treatment option in such areas.
- Swale side slopes are typically 1:9. For maintenance, grassed swales requiring mowing must not have side slopes exceeding 1:4
- Should be in accordance with the guidelines set out in Chapter 8 (Clause 8.3) of the Water Sensitive Urban Design Engineering Procedures: Stormwater Manual (Melbourne Water, 2005)
- Approved for use in open space reserves within a residential one zone, central median strips on roads subject to road reserve width and services.

11.3.6 Sand filters

The design requirements for sand filters should be in accordance with the guidelines set out in Chapter 7 (Clause 7.3) of the Water Sensitive Urban Design Engineering Procedures: Stormwater Manual (Melbourne Water, 2005).

11.3.7 Sedimentation basins

The design requirements for sedimentation basins are:

- The design operation discharge for the basin should be a minimum of 1 year ARI peak discharge
- A bypass structure should provide for flow bypass of downstream macrophyte zones and wetlands for events up to 100 year ARI event
- The sedimentation basin is to be designed to remove 95% of the particles less than 125 µm in a 1:1 year storm event
- Approach batter slopes should be no steeper than 1:5 vertical to Horizontal (V:H). All edges should have safety benches of at least 1.5m to 3m wide from the edge of the normal top water level

Infrastructure Design Standard

- Safety benches should have a maximum grade of 1:8(V:H) for the first 1.5m – 3m before changing to 1:5 (V:H) grade for at least the next 0.5m. Beyond this the grade may be to a maximum of 1:3 (V:H)
- An independent safety audit shall be conducted for each design.
- The hard stand should be at least 3m wide and be designed to be capable of supporting a 20 tonne excavation plant. Multiple areas should be considered where the pond is greater than 7m wide. Adequate space for dewatering must be provided. Access ramps and tracks into pond cells and to all hardstand areas are required and must be capable of supporting a 20 tonne excavation plant for maintenance.
- Where sedimentation basins double as a landscape element, a weir is recommended as an appropriate discharge control structure
- Install a rock layer in base above clay liner to indicate the limit of sediment, this reduces the risk of damage to the clay liner during future maintenance activities
- For sedimentation basins less than 14m wide, access is to be provided along both edges for maintenance vehicles
- For sedimentation basins greater than 14m wide, drawdown of the basin is required with vehicular access available in the base of the facility
- Should be in accordance with the guidelines set out in Chapter 4 (Clause 4.3) of the Water Sensitive Urban Design Engineering Procedures: Stormwater Manual (Melbourne Water, 2005)
- Not approved on steep land or as a permanent treatment where there is no maintenance regime in place to ensure regular removal of silt, debris etc.

11.3.8 Ponds and shallow lake systems

The design requirements for ponds and shallow lake systems are:

- When considering macrophyte layout it is important to optimise hydraulic efficiency ie., reduce dead zones and short circuiting of water. The optimal hydraulic efficiency value for constructed wetlands should be not less than 0.5 or greater than 0.7 where possible. Refer to Section 9.3.3 and Figure 9.6 in the Water Sensitive Urban Design Engineering Procedures: Stormwater Manual (Melbourne Water, 2005)
- Gentle slopes, safety benching, handrails and vegetation planting are methods that may be employed to account for public safety
- An independent safety audit must be conducted for each design
- Should be in accordance with the guidelines set out in Chapter 10 (Section 10.3) of the Water Sensitive Urban Design Engineering Procedures: Stormwater Manual (Melbourne Water, 2005)
- Not approved on steep land.

Infrastructure Design Standard

11.3.9 Rainwater tanks

The design requirements for rainwater tanks are:

- Continual water balance assessments using MUSIC should be performed to determine how much runoff rain tanks are removing from the catchment in terms of runoff volumes and associated pollutant loads
- Rainwater tanks should be sized using the appropriate reference curves for the region refer to Section 12.4.2 of the Water Sensitive Urban Design Engineering Procedures: Stormwater Manual (Melbourne Water, 2005)
- Should be in accordance with the guidelines set out in Chapter 12 (Section 12.2 and 12.4) of the Water Sensitive Urban Design Engineering Procedures: Stormwater Manual (Melbourne Water, 2005).

Infrastructure Design Standard

12 Stormwater discharge points

12.1 Objectives

Stormwater discharge points will be set by Council for all developments including subdivisions, industrial, commercial and residential developments.

Stormwater and legal points of discharge will be determined by Council having regard to the following objectives:

- The capacity of existing drainage infrastructure shall not be exceeded as a result of developments which increase the volume and rate of stormwater runoff beyond the capacities originally designed for
- The percentage increase of the stormwater flow being generated by the development when compared to the whole catchment
- The likely cumulative impact of similar developments shall not adversely impact on the capacity of the existing drainage system
- The ability to provide on-site detention in order to protect the existing drainage system capacity for the uses and areas it was designed for
- The location of the nearest drainage system capable of taking the stormwater flow from the development shall be considered in determining the stormwater discharge point having regard to the cost and effectiveness of draining to that point
- Any new drain required to be constructed should be assessed from the perspective of serving other lands that may carry out similar developments to avoid future duplications. Equitable cost sharing arrangements will need to be determined should drain sizes be increased to service other properties in the future
- The requirement to treat stormwater and to ensure stormwater runoff does not adversely impact on the environment and surrounding properties.

12.2 General

Due to the fact that drainage systems have been designed to different design standards and the fact that developments have taken place that have increased the volume and rate of stormwater runoff beyond what the designers catered for there is a need to determine the impact of new developments on the existing drainage systems prior to allowing them to discharge directly into these systems.

It is important to ensure that more frequent flooding does not occur and that existing drainage problems are not increased as a result of new developments.

Council may need to determine the impact of new developments on existing drainage systems prior to determining the legal point of discharge. The impact will need to be assessed from both a volumetric and rate of flow perspectives.

Where the impact is likely to cause increased flooding frequency or flooding extent then Council shall determine what works are necessary for a particular point in a drainage system to be the nominated point of discharge.

Infrastructure Design Standard

12.3 Requirements

Applications for nomination of point of discharge for dwellings should include the following information:

- Plan showing the proposed development including the pervious and impervious areas
- Existing and proposed surface levels at an interval not exceeding 10m
- Location and size of existing drains and easements within and adjacent to the site.

Applications for nomination of point of discharge for other developments should include the following information:

- Plan showing the proposed development including the pervious and impervious areas
- Existing and proposed surface levels at an interval not exceeding 10m
- Description of the proposed development
- Locality plan showing the development location and catchment boundaries
- Location and size of existing drains and easements and reserves within and adjacent to the development
- Drainage rights and/or easements shall be obtained by the developer's representative from all downstream owners who may be affected by the discharge of stormwater wherever the point of discharge is not to either a Council-owned drain or watercourse.

Where Council determines that the development is likely to adversely impact the existing drainage system Council may require the designer to provide further information including computations to determine the works that are necessary to minimise the impact of the development on the existing drainage system.

Where on-site detention is required this will be designed in accordance with the requirements of Section 10 - Small detention systems.

Infrastructure Design Standard

13 Associated infrastructure

13.1 Objectives

The objectives of associated infrastructure are:

- All associated infrastructure that is to be vested in Council shall meet Council's requirements and standards as set out in this IDS
- In giving approval for associated infrastructure, Council shall have regard to any future maintenance and operating costs, the likely availability of replacement parts and conformity with any Council policy or strategy eg., greenhouse emissions.
- The urban character and amenity of a locality neighbourhood or development shall not be adversely impacted by the proposed associated infrastructure
- The location of the proposed associated infrastructure shall not conflict with other existing or proposed services and Council infrastructure
- The requirements of all servicing authorities are considered before giving approval for any particular service
- The requirements of any relevant Codes of Practice, Australian Standard, Regulation or Act of parliament is considered by Council before approving the type and location of any associated infrastructure.

13.2 General

The design, documentation and installation of all related infrastructure required to service the development shall be in accordance with the relevant authority criteria, specifications and instructions.

13.3 Telecommunications

The design, documentation and installation of all related infrastructure required to service the development shall be in accordance with the relevant Authority criteria, specifications and instructions.

The consultant/developer shall be responsible to liaise and coordinate with the authority responsible for telecommunications, the design and construction of the required infrastructure, in association with all other works required for the development.

13.4 Water and sewer

The design, documentation and installation of all related infrastructure required to service the development shall be in accordance with Eurobodalla Shire Council's Water and Sewer Specification and instructions.

The location and spacing of fire hydrants to be as set out in Council's Water Specification.

Infrastructure Design Standard

13.5 Electrical

The design, documentation and installation of all electrical Infrastructure required to service the development shall be in accordance with the authority responsible for electrical, specifications and instructions.

For commercial and industrial developments a power supply plan shall be provided documenting the supply standard for each lot.

Detailed requirements for public lighting are presented in Section 14 – Public lighting of this IDS.

Infrastructure Design Standard

14 Public lighting

14.1 Objectives

The objective of this section is to ensure the consistent, equitable and environmentally responsible provision of public lighting and to provide public lighting to the appropriate standards that considers the safety and security of all sectors of the community.

14.2 Provision for public lighting

All roads within the new subdivision shall be provided with public lighting in accordance with the requirements of the relevant Australian Standards. New lighting shall be located outside the Clear Zones wherever possible, and shall meet the standards for Category V or Category P lighting, as appropriate.

Category V lighting is applicable on roads where visual requirements of motorists are dominant, such as sub-arterial roads. Category P lighting is applicable on roads and other public outdoor areas where the visual requirements of pedestrians are dominant, such as local roads and outdoor shopping precincts.

All public lighting must incorporate the use of energy efficient globes eg., T5, CF42.

14.3 Lighting design

Lighting design shall be in accordance with the relevant Australian Standards, including the current issue of AS/ANZ 1158.

Lighting installations for RMS controlled roads and associated intersections are reviewed and approved by the RMS as the responsible coordinating road authority. Copies of drawings shall be forwarded to Council for assessment after which advice will be forwarded to RMS prior to approval.

Allowance for pole locations shall be provided within all road reserves and offsets are to be shown in service location tables on functional layout plans and road construction plans.

A minimum 800mm offset shall be provided from back of kerb to pole for all roads with P Category lighting, including laneways and shared zones where kerbing is provided.

A minimum 1m clearance is required from face of pole to:

- Edge of carriageway in laneways, shared zones and extended driveways where no kerbing is provided. Kerb outstands may be requested for pole protection in some circumstances.
- Edge of pram crossings and private vehicle crossings within nature strips, Easy Fit pole bases/foundations are required where maintenance access is restricted eg., in laneways, paper roads and shared driveways).

With the exception of lighting in speed zones of 50 kph or less, frangible poles shall be adopted for roads with V Category lighting in accordance with AS 1158. The specific pole type, impact absorbing or slip base, shall be determined according to RMS standards and must be nominated on the drawings.

Infrastructure Design Standard

Provision of public lighting is required for all principal footpaths and bike paths within parks and reserves of any development. All cabling for this purpose shall be from a metered point of supply at the reserve boundary and Council will accept responsibility for the tariff.

Bollard lighting is acceptable only in reserves where vertical illumination is not required for the relevant lighting category.

Lighting obstructions eg., (from existing large trees) shall be taken into account when locating poles and assessing luminance requirements.

The requirements for the provision of street lighting areas zoned E4 & R5 shall, as a minimum, provide one light at intersections and one at the end of the cul-de-sac head. This number may be reduced for short cul-de-sacs where it can be demonstrated that lesser lighting is sufficient.

It is important to note that the amount and type of lighting, including recommended light technical parameters, in any external public area, is driven by three main considerations:

- The type and quantity of pedestrian and vehicular traffic in the area to facilitate safe movement
- The security risk of the area to discourage illegal acts
- The need to enhance the amenity of the area to increase aesthetic appeal.

14.4 Pre-submission requirements

Prior to the submission of public lighting plans the following shall be confirmed with Council:

- Lighting design categories for all roads and pathways
- Locations of all principal pathways in parks/reserves outside road reserves
- Locations and type of other items/structures that may require public lighting.

For any lighting type not previously accepted by Council provide full information on the proposed pole and lantern together with details of the current supply and delivery cost of a single unit and likely availability into the future ie., (regular stock or limited production line).

A functional layout plan has been endorsed in accordance with the development consent.

Infrastructure Design Standard

15 Tables

Table 1 – Acceptable scales and sheet sizes	10
Table 2 – Urban street/road characteristics	15
Table 3 – Sight stopping distance target speeds	18
Table 4 – Limiting longitudinal grades	18
Table 5 – Rural road characteristics	21
Table 6 – Typical rural road desired speeds	22
Table 7 - Land use impervious percentages	39
Table 8 - Minor drainage system design ARI	39
Table 9 - Frequency factors (FF_y)	40
Table 10 - Pipe roughness values	41
Table 11 - Minimum pipe cover	42
Table 12 - Gabion sizing	46
Table 13 - Absorption pit capacities	48
Table 14 - Rural drainage culvert ARI capacities	52
Table 15 - IFD zone 1 data	77
Table 16 - IFD zone 2 data	78
Table 17 - IFD zone 3 data	79
Table 18 – IFD zone 4 data	80
Table 19 – Hydrological design sheet 1	90
Table 20 – Hydrological design sheet 2	91
Table 21 – Hydrological design sheet 3	92
Table 22 – Hydraulic design sheet	93

Infrastructure Design Standard

16 Appendix A - Stormwater

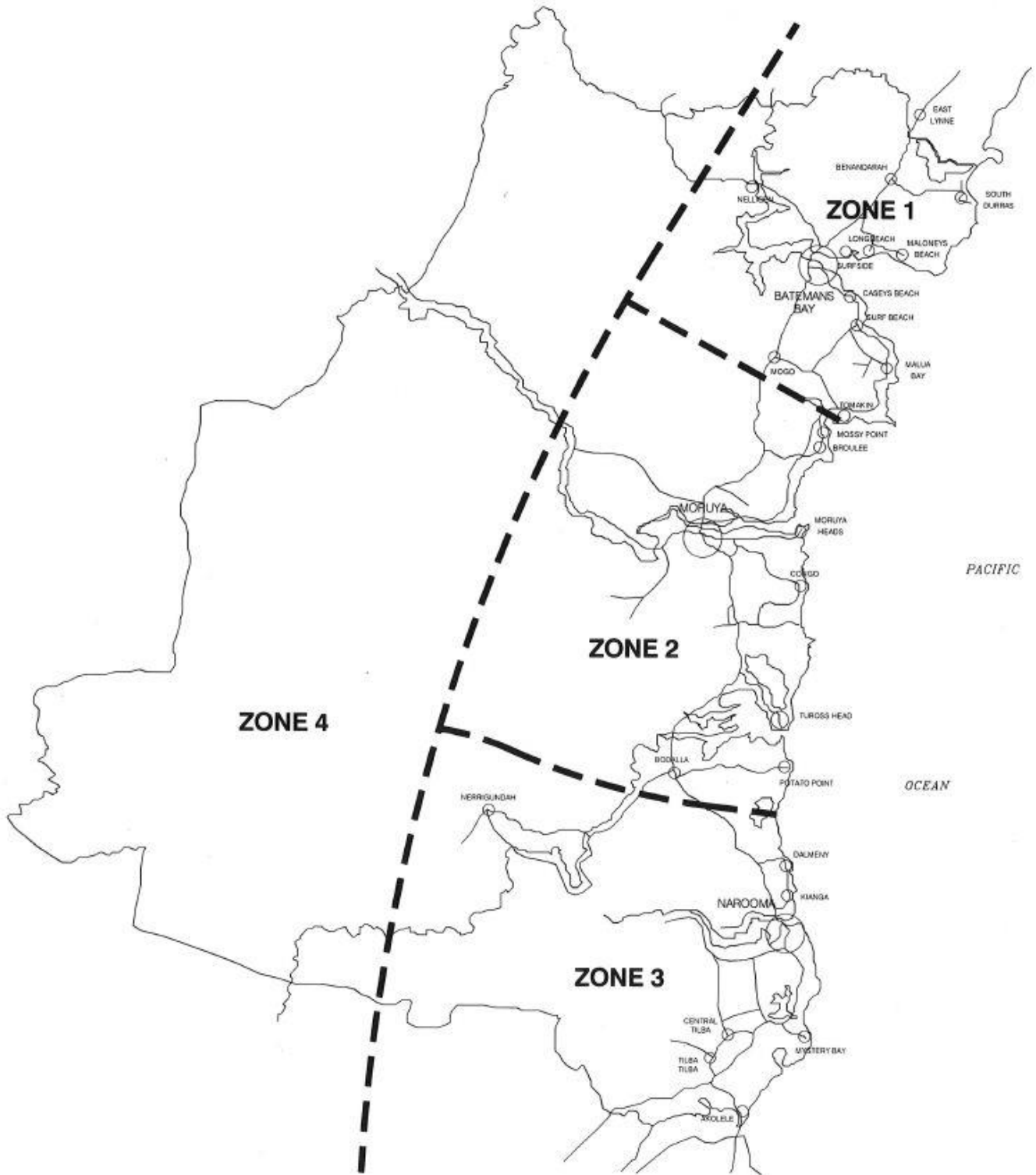

Figure 2- IFD zones

Infrastructure Design Standard

Duration mins	1 Yr ARI mm/hr	2 Yr ARI mm/hr	5 Yr ARI mm/hr	10 Yr ARI mm/hr	20 Yr ARI mm/hr	50 Yr ARI mm/hr	100 Yr ARI mm/hr
5	96	125	162	184	213	252	282
6	90	117	152	173	201	238	267
7	85	111	144	164	191	226	254
8	81	105	137	157	182	217	243
9	77	101	132	150	175	208	234
10	74	96	126	144	168	200	225
11	71	93	122	139	162	193	218
12	69	89	117	135	157	187	211
13	66	86	114	130	152	182	204
14	64	83	110	126	148	176	199
15	62	81	107	123	144	172	194
16	60	79	104	120	140	167	189
17	59	76	101	116	136	163	184
18	57	74	99	114	133	159	180
19	56	73	96	111	130	156	176
20	54	71	94	108	127	152	172
21	53	69	92	106	125	149	169
22	52	68	90	104	122	146	166
23	51	66	88	102	120	144	162
24	49.5	65	86	100	117	141	160
25	48.5	63	85	98	115	138	157
26	47.5	62	83	96	113	136	154
27	46.6	61	82	95	111	134	152
28	45.8	60	80	93	109	132	149
29	44.9	59	79	91	108	130	147
30	44.1	58	78	90	106	128	145
32	42.7	56	75	87	103	124	141
34	41.3	54	73	85	100	120	137
36	40.1	53	71	82	97	117	133
38	38.9	51	69	80	95	114	130
40	37.8	49.8	67	78	92	112	127
45	35.5	46.7	63	74	87	106	120
50	33.5	44.1	60	70	83	100	114
55	31.7	41.8	57	67	79	96	109
60	30.2	39.8	54	64	75	92	105
75	26.4	34.8	47.6	56	66	80	91
90	23.6	31.2	42.6	49.7	59	72	82
105	21.5	28.4	38.7	45.2	54	65	74
120	19.8	26.1	35.6	41.6	49.4	60	68
150	17.2	22.7	31	36.2	42.9	52	59
180	15.4	20.3	27.6	32.3	38.3	46.5	53
210	14	18.4	25.1	29.3	34.7	42.2	48.1
240	12.8	16.9	23.1	26.9	31.9	38.8	44.2
270	11.9	15.7	21.4	25	29.7	36	41
300	11.2	14.7	20	23.4	27.8	33.7	38.4
360	9.96	13.1	17.9	20.9	24.7	30	34.2
420	9.05	11.9	16.2	19	22.5	27.3	31
480	8.32	11	14.9	17.4	20.7	25.1	28.5
540	7.74	10.2	13.9	16.2	19.2	23.3	26.5
600	7.25	9.55	13	15.2	18	21.8	24.8
720	6.47	8.52	11.6	13.5	16	19.4	22.1
840	5.87	7.75	10.6	12.4	14.7	17.8	20.3
960	5.4	7.13	9.76	11.4	13.6	16.5	18.8
1080	5.02	6.63	9.09	10.6	12.7	15.4	17.6
1200	4.69	6.21	8.53	10	11.9	14.5	16.6
1440	4.18	5.53	7.63	8.96	10.7	13	14.9
1800	3.61	4.8	6.64	7.82	9.34	11.4	13.1
2160	3.2	4.26	5.92	6.98	8.36	10.2	11.8
2520	2.89	3.84	5.35	6.33	7.58	9.32	10.7
2880	2.63	3.5	4.9	5.8	6.96	8.56	9.84
3240	2.42	3.23	4.52	5.36	6.44	7.93	9.13
3600	2.24	2.99	4.2	4.99	6	7.4	8.52
4320	1.95	2.61	3.69	4.39	5.28	6.53	7.53

Table 15 - IFD zone 1 data

Infrastructure Design Standard

Duration mins	1 Yr ARI mm/hr	2 Yr ARI mm/hr	5 Yr ARI mm/hr	10 Yr ARI mm/hr	20 Yr ARI mm/hr	50 Yr ARI mm/hr	100 Yr ARI mm/hr
5	91	118	156	179	210	251	283
6	85	111	147	169	198	237	268
7	80	105	139	161	188	226	255
8	76	100	133	153	180	216	244
9	73	95	127	147	172	207	235
10	70	91	122	141	166	200	226
11	67	88	117	136	160	193	219
12	64	84	113	131	155	187	212
13	62	81	110	127	150	181	205
14	60	79	106	123	146	176	200
15	58	76	103	120	142	171	194
16	56	74	100	117	138	167	190
17	55	72	98	114	134	163	185
18	53	70	95	111	131	159	181
19	52	68	93	108	128	155	177
20	51	67	91	106	125	152	173
21	49.5	65	89	104	123	149	170
22	48.4	64	87	101	120	146	166
23	47.3	62	85	99	118	143	163
24	46.3	61	83	97	116	140	160
25	45.4	60	82	96	113	138	157
26	44.5	59	80	94	111	136	155
27	43.6	58	79	92	110	133	152
28	42.8	57	77	91	108	131	150
29	42	56	76	89	106	129	147
30	41.3	55	75	88	104	127	145
32	39.9	53	72	85	101	123	141
34	38.6	51	70	83	98	120	137
36	37.5	49.6	68	80	96	117	134
38	36.4	48.2	66	78	93	114	130
40	35.4	46.9	65	76	91	111	127
45	33.2	44	61	72	86	105	120
50	31.3	41.5	58	68	81	100	115
55	29.6	39.4	55	65	78	95	109
60	28.2	37.5	52	62	74	91	105
75	24.7	32.9	45.7	54	65	79	91
90	22.2	29.5	40.9	48.3	58	71	81
105	20.2	26.9	37.2	43.9	52	64	74
120	18.7	24.8	34.2	40.3	48.2	59	68
150	16.3	21.6	29.8	35	41.8	51	58
180	14.6	19.3	26.6	31.2	37.2	45.4	52
210	13.3	17.6	24.1	28.3	33.7	41.1	47
240	12.2	16.2	22.2	26	30.9	37.7	43.1
270	11.4	15	20.6	24.1	28.7	34.9	39.9
300	10.7	14.1	19.3	22.5	26.8	32.6	37.2
360	9.54	12.6	17.2	20.1	23.8	29	33.1
420	8.69	11.5	15.6	18.2	21.6	26.2	29.9
480	8.01	10.6	14.3	16.7	19.8	24.1	27.4
540	7.45	9.82	13.3	15.5	18.4	22.3	25.4
600	6.99	9.2	12.5	14.5	17.2	20.8	23.7
720	6.26	8.23	11.1	13	15.3	18.5	21.1
840	5.7	7.5	10.2	11.9	14	17	19.4
960	5.25	6.92	9.41	11	13	15.8	18
1080	4.89	6.45	8.79	10.3	12.2	14.8	16.9
1200	4.58	6.05	8.26	9.66	11.5	13.9	15.9
1440	4.09	5.41	7.41	8.68	10.3	12.6	14.4
1800	3.56	4.71	6.48	7.61	9.07	11.1	12.7
2160	3.16	4.19	5.79	6.81	8.13	9.95	11.4
2520	2.86	3.79	5.26	6.19	7.4	9.07	10.4
2880	2.61	3.47	4.82	5.69	6.81	8.35	9.59
3240	2.41	3.2	4.46	5.27	6.32	7.76	8.91
3600	2.24	2.98	4.15	4.92	5.89	7.25	8.33
4320	1.96	2.61	3.66	4.34	5.21	6.42	7.39

Table 16 - IFD zone 2 data

Infrastructure Design Standard

Duration mins	1 Yr ARI mm/hr	2 Yr ARI mm/hr	5 Yr ARI mm/hr	10 Yr ARI mm/hr	20 Yr ARI mm/hr	50 Yr ARI mm/hr	100 Yr ARI mm/hr
5	92	119	156	178	208	247	278
6	86	112	147	168	196	234	263
7	81	106	139	159	186	222	251
8	77	100	132	152	178	212	240
9	74	96	127	146	170	204	230
10	70	92	122	140	164	196	221
11	68	88	117	135	158	189	214
12	65	85	113	130	153	183	207
13	63	82	109	126	148	178	201
14	61	80	106	122	144	172	195
15	59	77	103	119	140	168	190
16	57	75	100	116	136	163	185
17	56	73	97	113	132	159	180
18	54	71	95	110	129	155	176
19	53	69	93	107	126	152	172
20	52	68	90	105	123	149	169
21	50	66	88	102	121	146	165
22	49.1	64	87	100	118	143	162
23	48.1	63	85	98	116	140	159
24	47.1	62	83	96	114	137	156
25	46.1	61	81	95	112	135	153
26	45.2	59	80	93	110	132	150
27	44.3	58	79	91	108	130	148
28	43.5	57	77	90	106	128	145
29	42.7	56	76	88	104	126	143
30	42	55	75	87	102	124	141
32	40.6	53	72	84	99	120	137
34	39.3	52	70	82	97	117	133
36	38.1	50	68	79	94	114	130
38	37	48.8	66	77	91	111	126
40	36	47.4	64	75	89	108	123
45	33.7	44.5	61	71	84	102	117
50	31.8	42	57	67	80	97	111
55	30.2	39.9	55	64	76	93	106
60	28.7	38	52	61	73	89	101
75	25	33.1	45.3	53	63	77	88
90	22.3	29.5	40.4	47.3	56	69	78
105	20.3	26.8	36.6	42.9	51	62	71
120	18.6	24.6	33.6	39.4	46.8	57	65
150	16.2	21.3	29.1	34.1	40.5	49.2	56
180	14.4	19	25.9	30.3	35.9	43.7	49.9
210	13	17.2	23.4	27.4	32.5	39.5	45
240	12	15.8	21.5	25.1	29.8	36.2	41.3
270	11.1	14.6	19.9	23.2	27.6	33.5	38.2
300	10.4	13.7	18.6	21.7	25.7	31.3	35.6
360	9.22	12.1	16.5	19.3	22.8	27.7	31.6
420	8.35	11	14.9	17.4	20.7	25.1	28.6
480	7.67	10.1	13.7	16	18.9	23	26.2
540	7.11	9.37	12.7	14.8	17.5	21.3	24.2
600	6.65	8.76	11.9	13.8	16.4	19.9	22.6
720	5.92	7.79	10.6	12.3	14.6	17.6	20.1
840	5.38	7.08	9.61	11.2	13.3	16.1	18.3
960	4.95	6.52	8.86	10.3	12.3	14.9	17
1080	4.59	6.06	8.25	9.63	11.4	13.9	15.8
1200	4.3	5.67	7.73	9.04	10.7	13	14.9
1440	3.83	5.05	6.91	8.08	9.6	11.7	13.3
1800	3.31	4.38	6	7.03	8.37	10.2	11.6
2160	2.94	3.89	5.34	6.26	7.46	9.1	10.4
2520	2.65	3.5	4.82	5.67	6.75	8.25	9.44
2880	2.41	3.2	4.41	5.18	6.18	7.56	8.65
3240	2.22	2.94	4.06	4.78	5.71	6.99	8
3600	2.06	2.73	3.77	4.44	5.31	6.5	7.45
4320	1.79	2.38	3.3	3.89	4.66	5.71	6.55

Table 17 - IFD zone 3 data

Infrastructure Design Standard

Duration mins	1 Yr ARI mm/hr	2 Yr ARI mm/hr	5 Yr ARI mm/hr	10 Yr ARI mm/hr	20 Yr ARI mm/hr	50 Yr ARI mm/hr	100 Yr ARI mm/hr
5	81	106	145	170	202	245	280
6	75	100	136	160	190	232	265
7	71	94	129	152	181	220	252
8	68	89	123	145	172	210	241
9	64	85	118	138	165	202	231
10	62	82	113	133	159	194	223
11	59	79	109	128	153	188	215
12	57	76	105	124	148	181	208
13	55	73	101	120	143	176	202
14	53	71	98	116	139	171	196
15	51	68	95	113	135	166	191
16	49.9	66	93	110	131	162	186
17	48.5	65	90	107	128	158	181
18	47.2	63	88	104	125	154	177
19	45.9	61	86	102	122	150	173
20	44.8	60	84	99	119	147	170
21	43.7	58	82	97	117	144	166
22	42.7	57	80	95	114	141	163
23	41.8	56	78	93	112	138	160
24	40.9	55	77	91	110	136	157
25	40	53	75	89	108	133	154
26	39.2	52	74	88	106	131	151
27	38.4	51	72	86	104	129	149
28	37.7	50	71	85	102	127	146
29	37	49.5	70	83	101	125	144
30	36.4	48.6	69	82	99	123	142
32	35.1	47	67	79	96	119	138
34	34	45.5	65	77	93	116	134
36	32.9	44.1	63	75	91	113	130
38	32	42.9	61	73	88	110	127
40	31.1	41.7	59	71	86	107	124
45	29.1	39.1	56	67	81	101	117
50	27.4	36.9	53	63	77	96	111
55	26	34.9	50	60	73	91	106
60	24.7	33.2	47.8	58	70	88	102
75	22.2	29.9	42.8	51	62	78	91
90	20.3	27.3	39.1	46.9	57	71	82
105	18.9	25.3	36.1	43.3	52	65	76
120	17.7	23.7	33.7	40.4	48.9	61	70
150	15.8	21.2	30.1	35.9	43.4	54	62
180	14.4	19.3	27.4	32.6	39.4	48.9	57
210	13.4	17.9	25.3	30.1	36.3	45	52
240	12.5	16.7	23.6	28.1	33.8	41.8	48.3
270	11.8	15.8	22.2	26.4	31.7	39.2	45.3
300	11.2	15	21	24.9	30	37.1	42.7
360	10.2	13.6	19.1	22.7	27.2	33.6	38.7
420	9.48	12.6	17.6	20.9	25.1	30.9	35.6
480	8.88	11.8	16.5	19.5	23.4	28.8	33.1
540	8.38	11.1	15.5	18.3	22	27	31
600	7.95	10.6	14.7	17.3	20.8	25.5	29.3
720	7.27	9.65	13.4	15.8	18.9	23.1	26.5
840	6.7	8.89	12.3	14.5	17.3	21.1	24.2
960	6.25	8.28	11.4	13.4	16	19.6	22.4
1080	5.87	7.77	10.7	12.5	14.9	18.3	20.9
1200	5.55	7.34	10.1	11.8	14.1	17.2	19.6
1440	5.03	6.65	9.09	10.6	12.6	15.4	17.6
1800	4.46	5.88	8	9.34	11.1	13.5	15.4
2160	4.03	5.31	7.19	8.38	9.93	12	13.7
2520	3.69	4.85	6.56	7.63	9.02	10.9	12.4
2880	3.41	4.49	6.04	7.02	8.29	10	11.4
3240	3.18	4.18	5.61	6.51	7.68	9.28	10.5
3600	2.99	3.91	5.25	6.08	7.16	8.64	9.8
4320	2.66	3.48	4.65	5.37	6.32	7.6	8.62

Table 18 - IFD zone 4 data

Infrastructure Design Standard

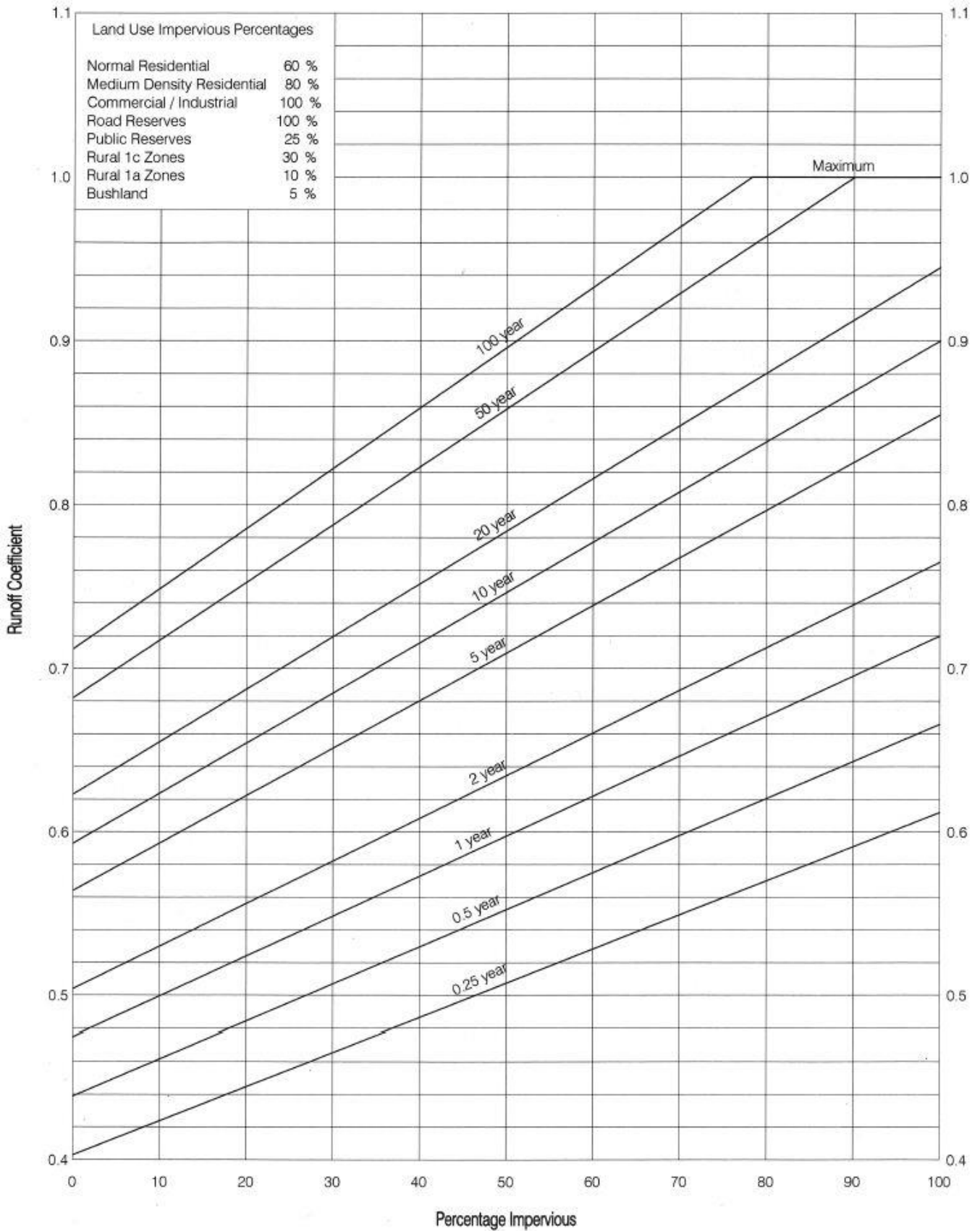
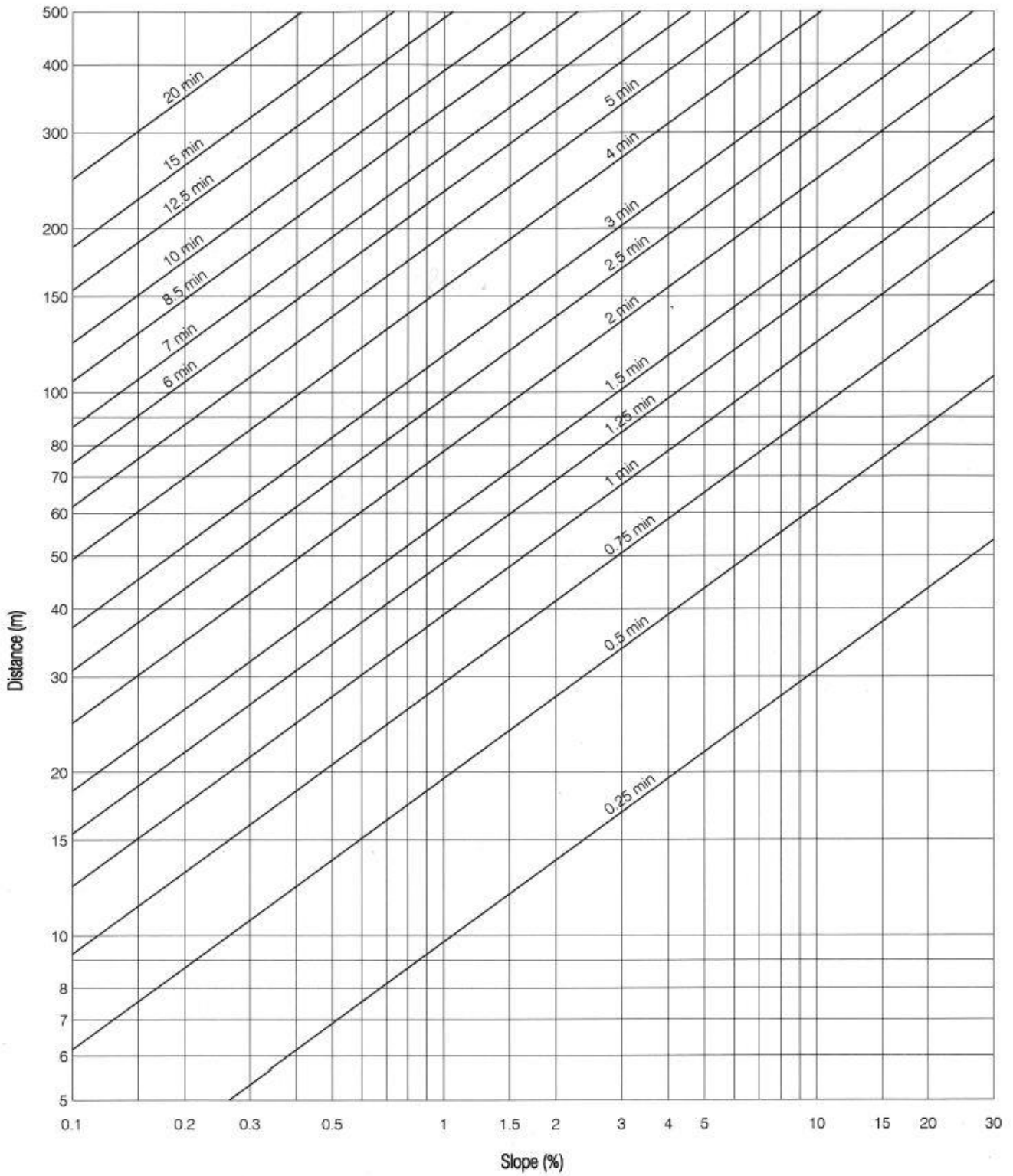

Figure 3 - Runoff coefficients

Infrastructure Design Standard



Time Multipliers

- 1 Pipes and concrete gutters
- 2 Blade cut and well maintained roadside earth drains
- 3 Natural channels
- 4 Grassed swales

Figure 4 - Channel flow times

Infrastructure Design Standard

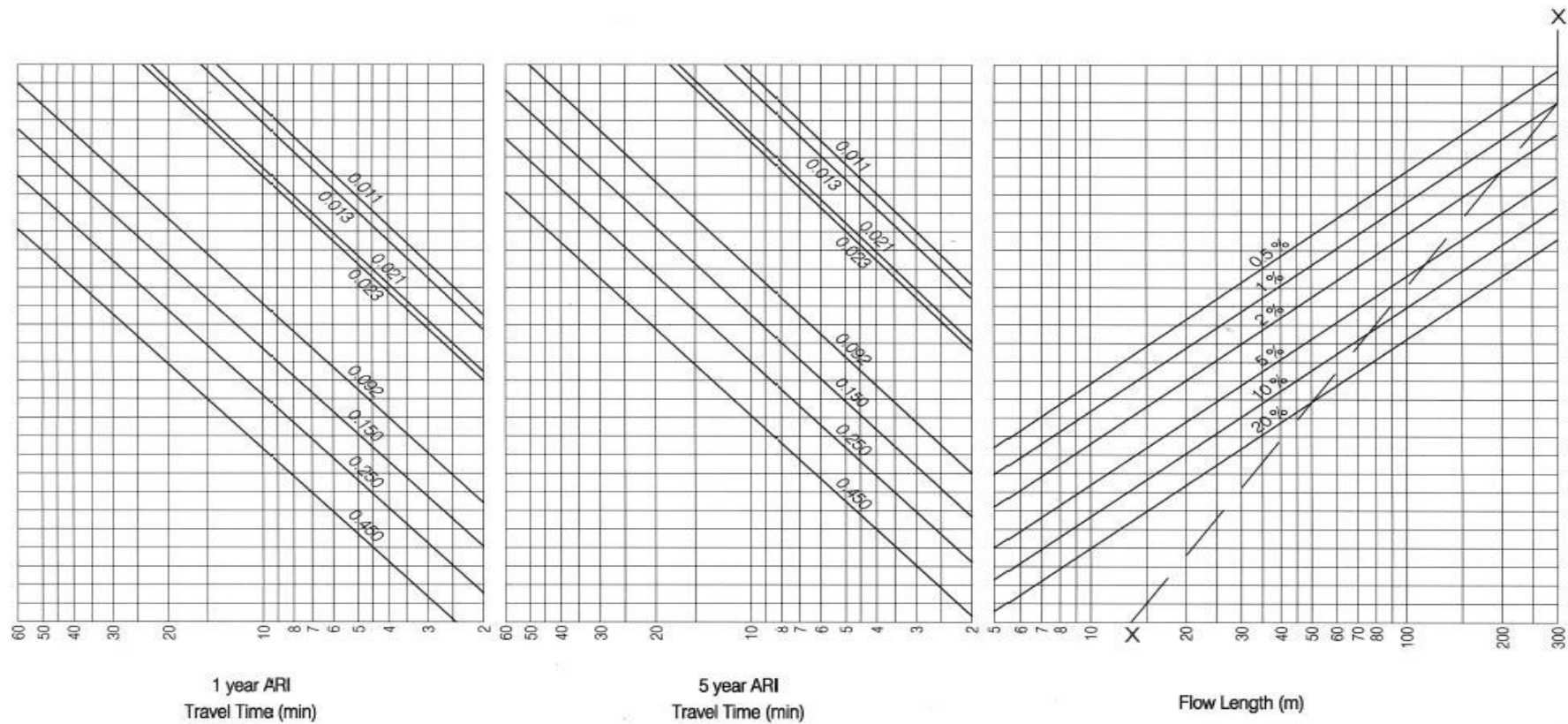

- Concrete/Asphalt 0.011
- Bare Sand 0.013
- Gravelled Surface 0.021
- Bare Clay 0.023
- Sparse Vegetation 0.092
- Short Grass 0.150
- Lawns 0.250
- Thickly Grassed 0.450

Note: The Boundary X-X defines the limit for sheet flow

Figure 5 - Kinematic wave – overland flow times - 1 & 5 year ARI

Infrastructure Design Standard

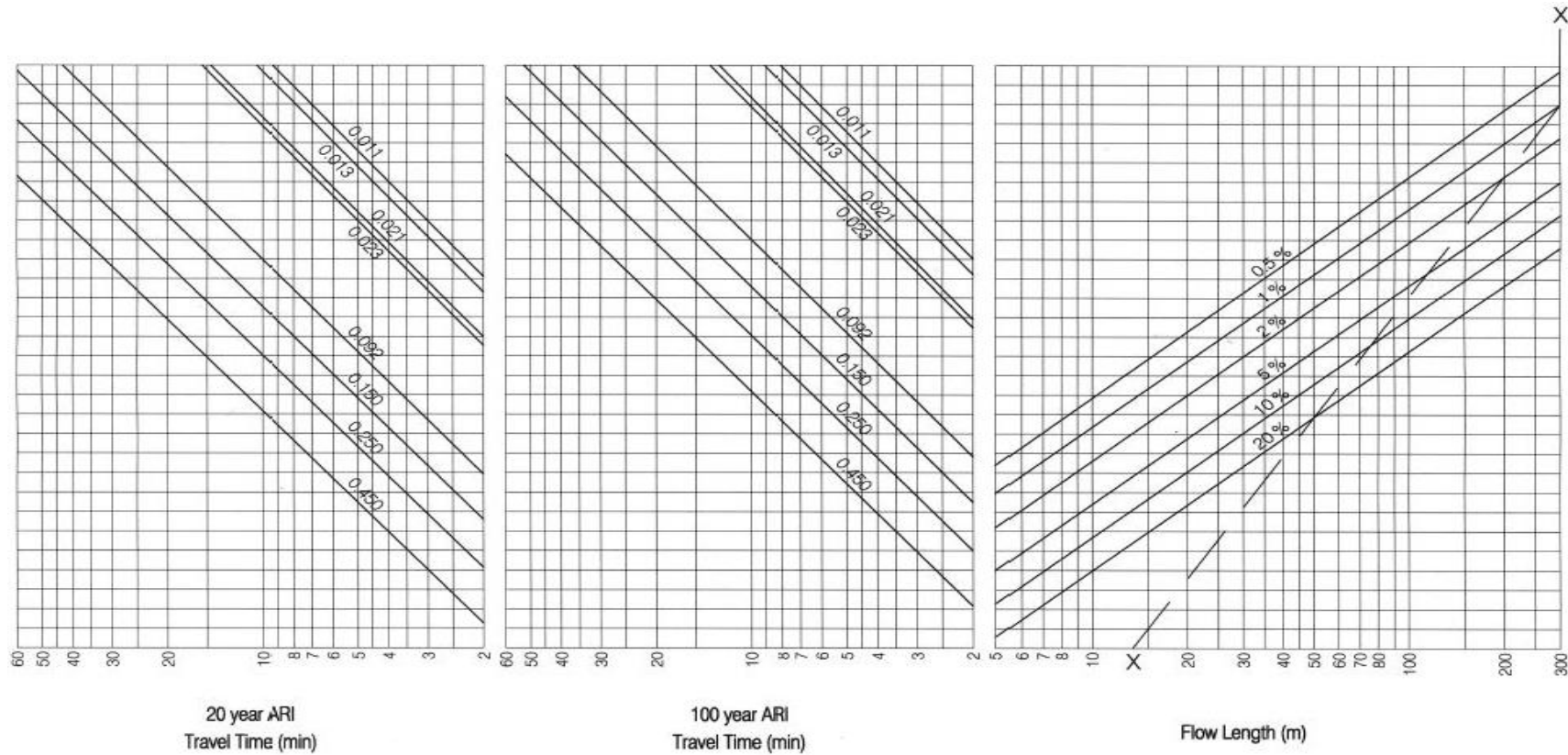

- Concrete/Asphalt 0.011
- Bare Sand 0.013
- Gravelled Surface 0.021
- Bare Clay 0.023
- Sparse Vegetation 0.092
- Short Grass 0.150
- Lawns 0.250
- Thickly Grassed 0.450

Note: The Boundary X-X defines the limit for sheet flow

Figure 6 - Kinematic wave – overland flow times - 20 & 100 year ARI

Infrastructure Design Standard

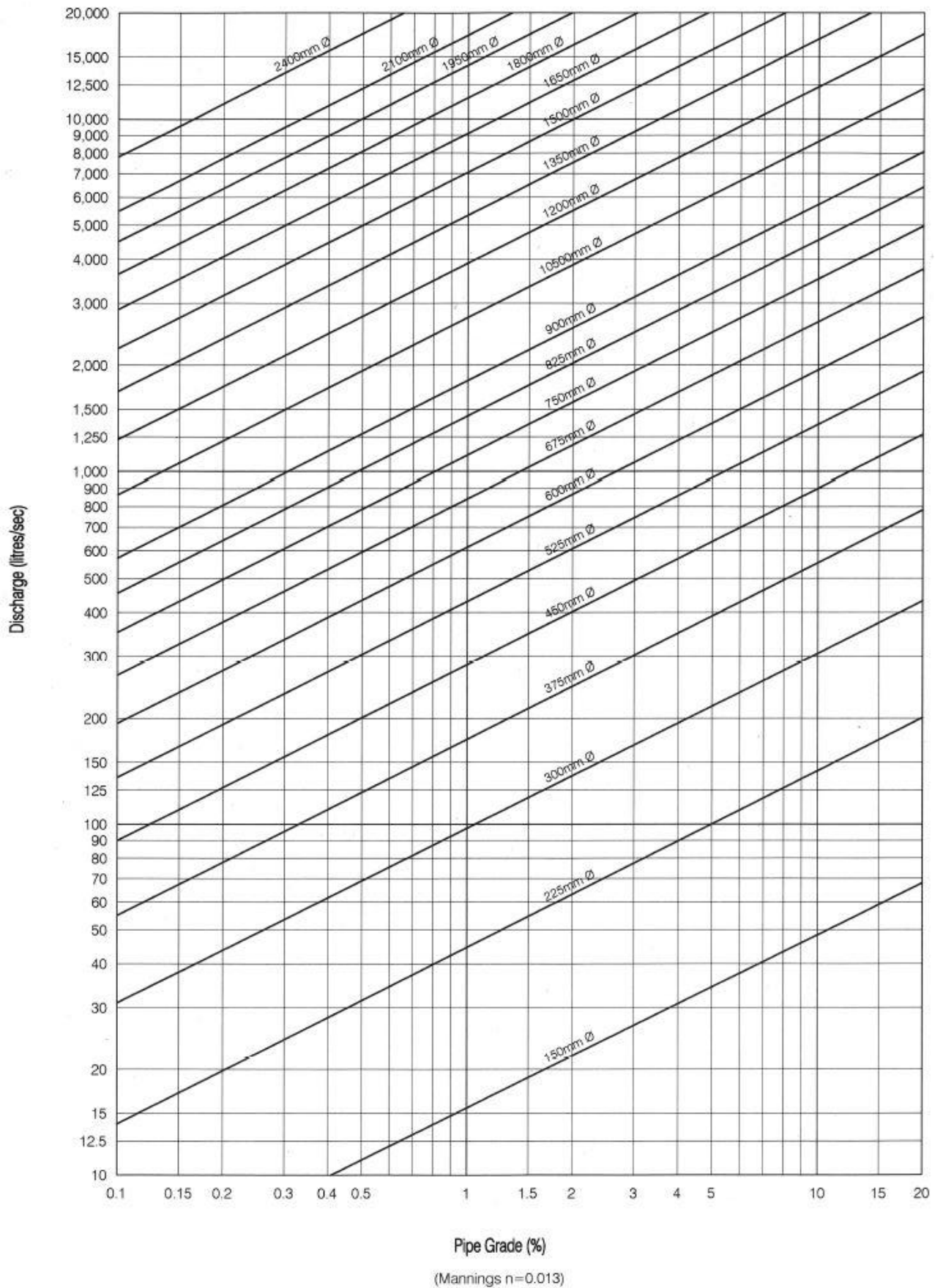

Figure 7 - Pipe flow discharge

Infrastructure Design Standard

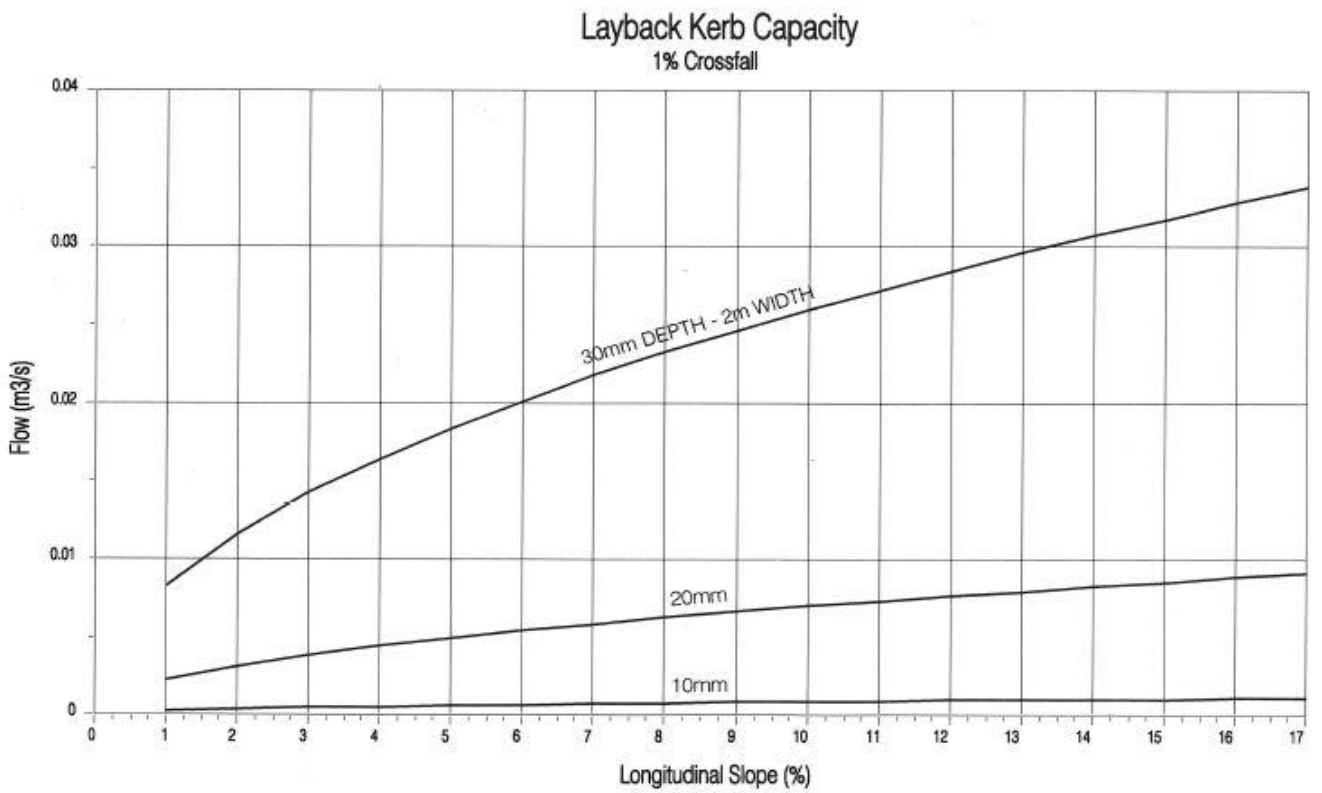
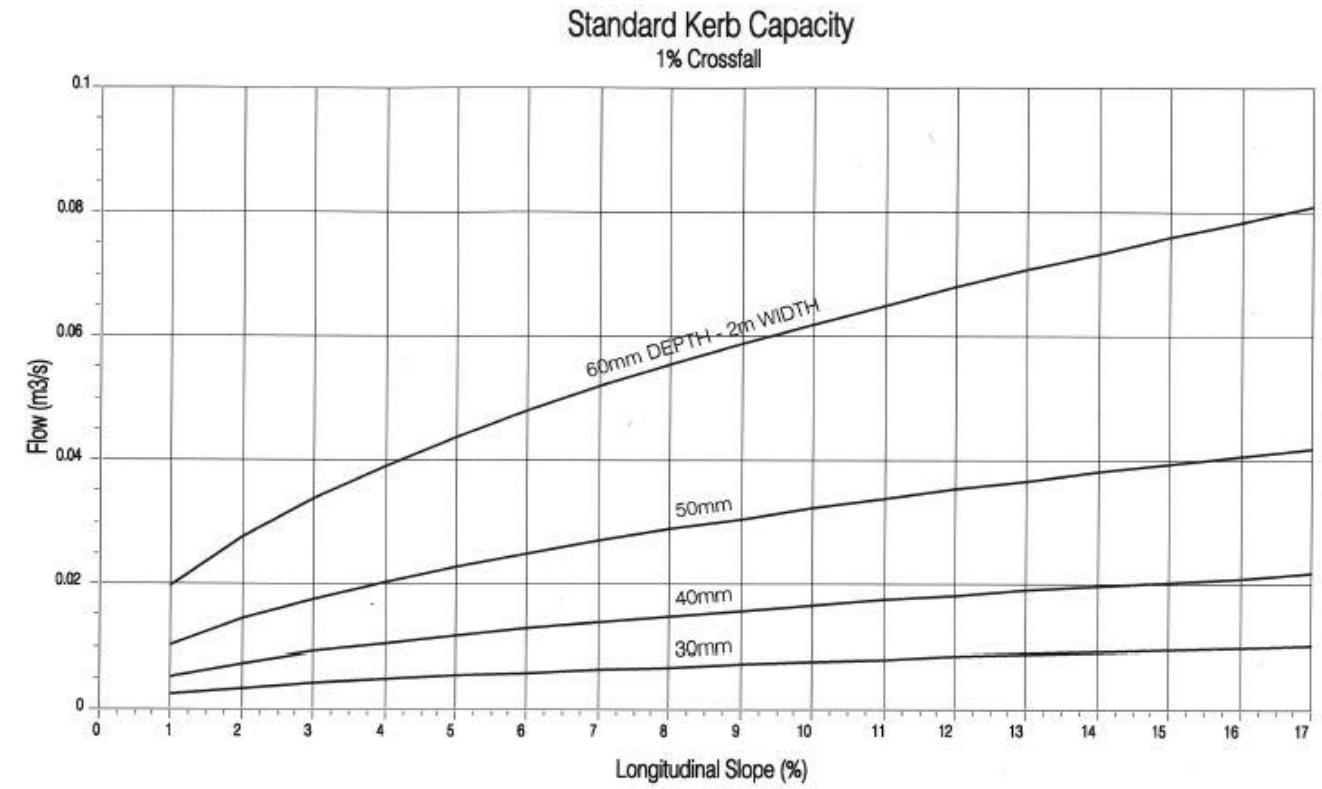
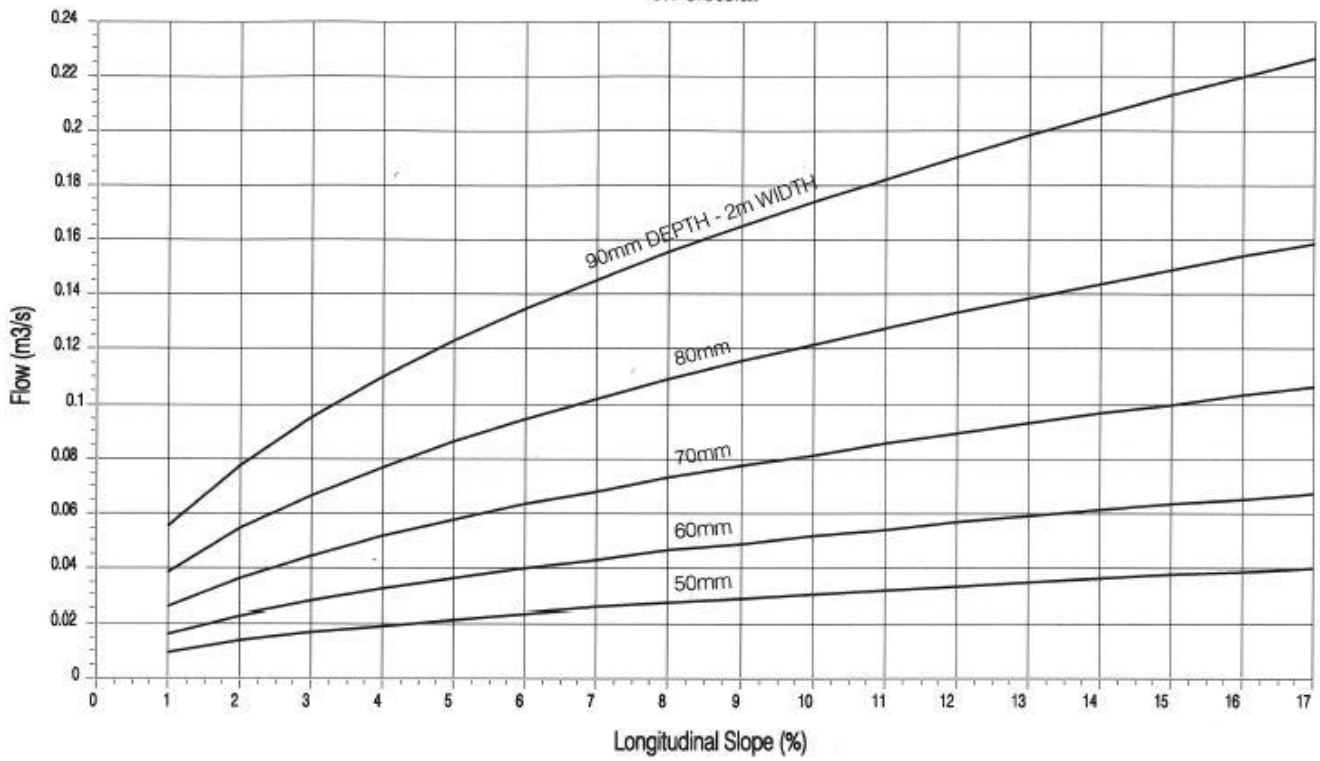

Figure 8 – Gutter flow capacity – 1% crossfall

Infrastructure Design Standard

Standard Kerb Capacity 3% Crossfall



Layback Kerb Capacity 3% Crossfall

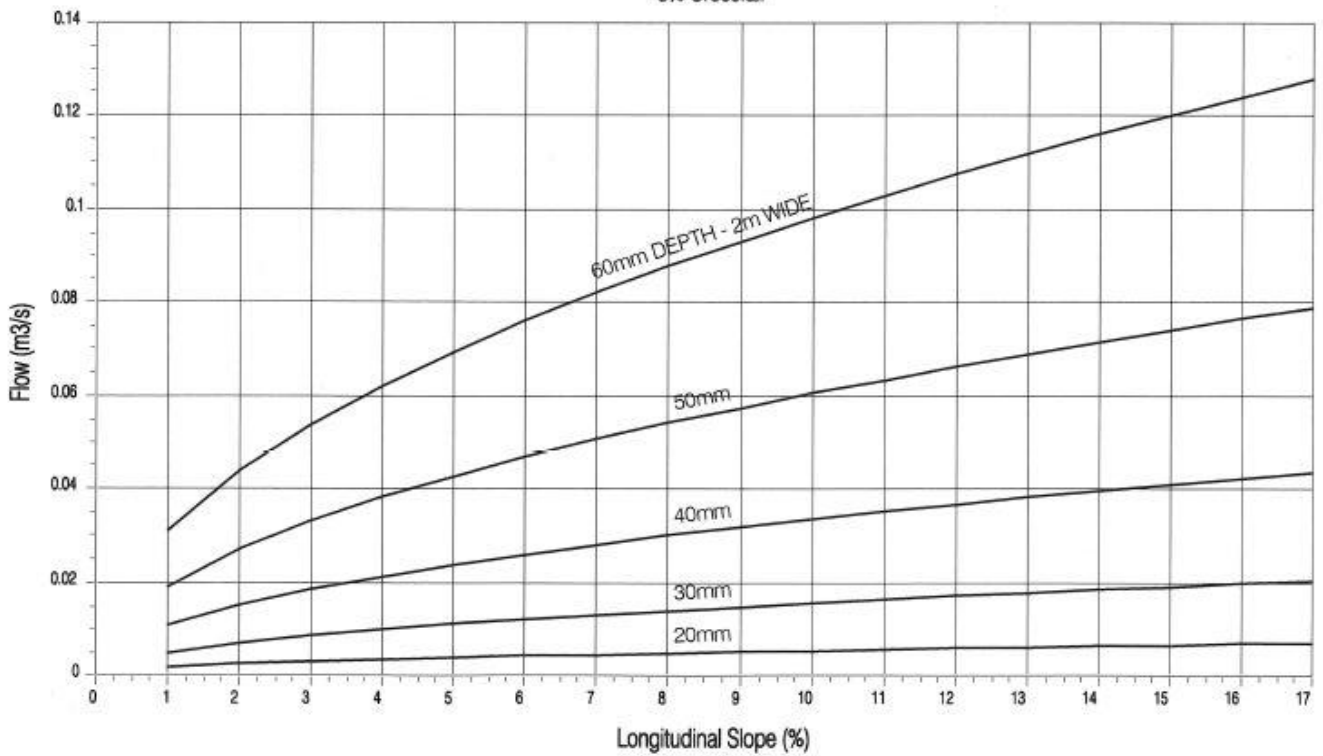
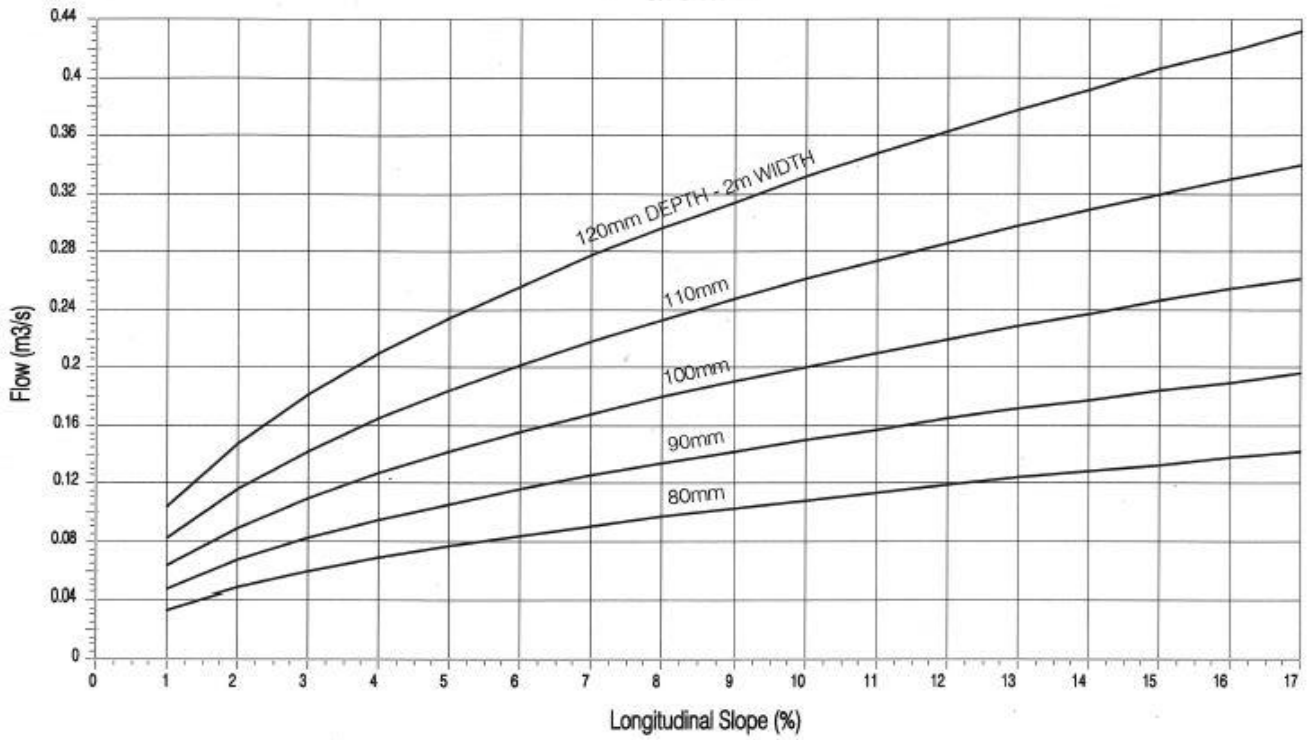

Figure 9 – Gutter flow capacity – 3% crossfall

Infrastructure Design Standard

Standard Kerb Capacity 5% Crossfall



Layback Kerb Capacity 5% Crossfall

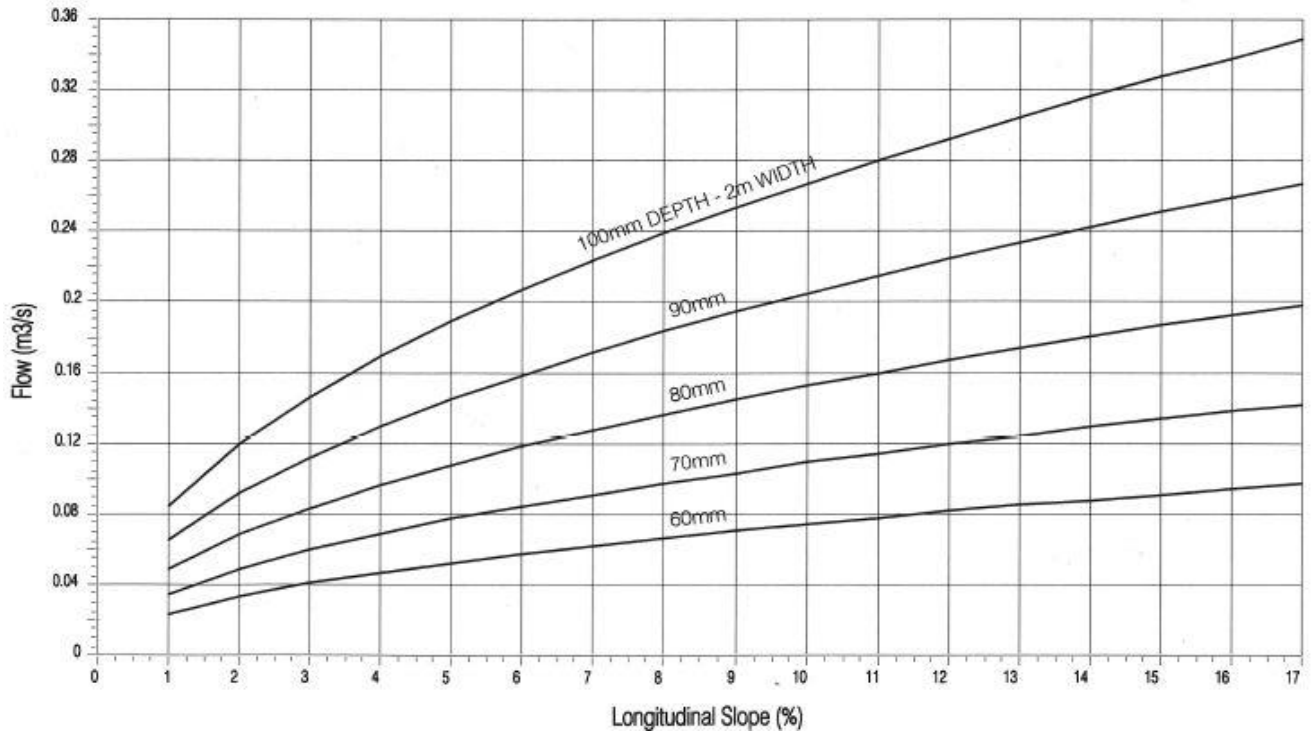
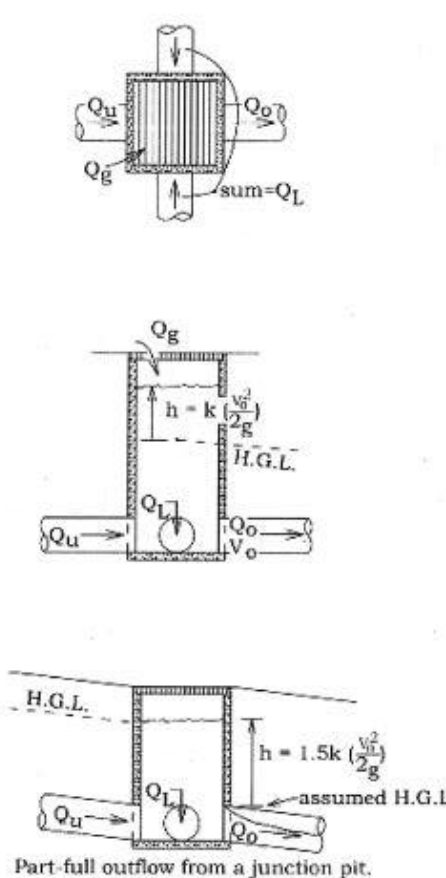

Figure 10 – Gutter flow capacity – 1% crossfall

Infrastructure Design Standard



DESCRIPTION	Qu	Ql	Qg	K
Inlet pit with one outlet pipe: (a) Side Entry (b) Grated Pit	- -	- -	-Qo -Qo	10 5
Inlet pit on through pipe	~0.9Qo ~0.7Qo ~0.5Qo	- - -	some -0.3Qo -0.5Qo	0.5 1.3 2.1
Junction pit on through pipe	-Qo	-	-	0.2
Inlet pit on through pipe with laterals	-0.9Qo ~0.7Qo ~0.5Qo ~0.2Qo	some some some	some some some	0.5 1.1 1.5 2.0
Junction pit on through pipe with laterals	-0.9Qo ~0.5Qo ~0.2Qo	some ~0.5Qo -0.8Qo	- - -	0.5 1.5 2.0
Inlet pit on L bend	-	-Qo	some	1.5
Junction pit on L bend	-	=Qo	-	1.3
Inlet pit on T junction with laterals	-	-Qo	some	1.8
Junction pit on T junction with laterals	-	=Qo	-	1.6
Drop pit (a) direction change less than 45 degrees (b) direction change more than 45 degrees	-Qo -Qo	- -	some some	2.0 2.5

NOTES

1. Qu = flow from upstream pipe; Qo = flow out of pit
Ql = flow from lateral pipes; Qg = flow from above the pit water level. K = pit head loss coefficient.
2. The pipes are assumed to operate below the water level in the pit. Flows entering from above the water surface should be added to Qg.
3. Where part full flow occurs in the outlet pipe, tests have shown that the water surface is significantly higher. Assume the hydraulic gradeline to be at the pipe invert, and add $h = 1.5 K V_o / 2g$.
4. Where the design flows are between the tabulated values, interpolate between the K values.
5. Where flow is deflected through a horizontal angle at a pit, add the coefficient from Figure 4.10 to the K value from this Figure 4.9, except at drop pits. for drop pits, use the values from Figure 4.9 above.
6. If D_u/D_o is less than 0.9 or better estimate of K is required, refer to design charts in Sangster et al.(1958).

Figure 11 – Average pit head loss factors

Infrastructure Design Standard

17 Appendix B – Information to be shown on plans

17.1 Minimum requirements for all plans

The following information shall be shown on all plans submitted to Council:

- Development or project title, including stage if applicable
- Planning permit reference if applicable
- Scales
- Plan No. and Sheet No.
- Schedule and date of amendments
- Signed design certification, by a qualified civil engineer or suitably qualified consultant
- Signed checking certification, by a qualified civil engineer.

17.2 Road layout plans

Road layout plans shall as a minimum show:

- North arrows aligned to top of page and appropriate scale bars
- Limit of works to be constructed including ALL connections to existing work
- All proposed allotments and reserves within the development
- Allotment numbers (numbers to be retained for final subdivision certificate) and dimensions
- All easements and land acquisitions
- All streets to be constructed, including proposed street names
- Existing and proposed PSM and TBM
- Chainages on traverse lines at all tangent points and cross-sections (at intervals of not more than 20m, along the centre line of roads)
- Kerb radii (to back of kerb) kerb type and offsets
- Footpaths, bicycle paths, and/or shared paths, and all pedestrian kerb crossings to concord with the Disability Discrimination Act. Levels shall be sufficiently documented to demonstrate compliance with requirements of AS 1428.
- Service conduit positions, including water, stormwater, telephone and electricity conduits where required (locations to be marked on footpaths or kerbs during construction)
- Locations of all existing driveways, drains, pits, services (existing and proposed) and poles
- Street name signs at all intersections
- All existing and proposed fill areas and depths of fill
- All probable or known slip areas and unstable area
- Set out detail for all horizontal curves

Infrastructure Design Standard

- Locations and description of roadside furniture and regulatory warning and guide signs where required, eg warrant sign plan for submission to Traffic Committee
- Linemarking
- Extent of sight benching
- Locations of culvert crossings and hard-standing areas for vehicle access into allotments.

17.3 Road longitudinal plans

Road longitudinal section plans shall as a minimum show the following:

- Centreline chainage
- Street name
- Centreline levels required at least every 20m, at all tangent points, changes of grade, low points and at each end of vertical curves
- Plot of each proposed top of kerb, back of path and existing surface level on title boundaries
- Length of vertical curves and intersection points
- Kerb and centreline grades
- Grading on rural roads to include a grading of table drains on the same section
- Location of intersecting streets and cul-de-sacs, including temporary cul-de-sacs for streets that are constructed in stages
- Road grading a minimum distance of 100m beyond the end of works
- Kerb levels shown on returns at quarter points in addition to tangent points. This may be tabulated as an alternative
- Kerb return grading showing the grading into the adjoining street. Note this is not required if detailed contours are provided
- In cul-de-sacs, grading of the kerb around the cul-de-sac head
- Level and location of all existing services to be in conflict with proposed works
- Datum RL
- Low points indicated.

17.4 Road cross-section plans

Cross-section shall be drawn for chainages at 20m. Cross-sections shall also be shown at all tangent points and at extreme changes in existing surface conditions. Road cross-section plans shall as a minimum show:

- Levels of existing surface for the full width of the road reserve
- Street name
- Design levels for kerb, footpaths and road pavement for urban works
- Position and level of crown of road
- Extent of batters and open drains

Infrastructure Design Standard

- Existing buildings on adjacent allotments and abutting streets, including floor levels
- Location and level of existing services (level where there is to be a conflict with proposed works)
- Road chainage of cross-section
- Datum RL
- Pavement boxing profile indicated (typical section)
- Road reserve boundary and details at title boundaries.

17.5 Typical road cross-sections

Typical cross-sections should be included in documentation where applicable and shall show the nature and location of the following:

- Profile and geometry of finished surface
- Location of subsoil drainage and conduits for services
- Details of footpath and road pavement profile
- Cut/fill batter slopes
- Kerb and channel type
- Kerb and channel offsets from title boundaries
- Drainage location
- Service infrastructure location and typical details
- Pavement materials, compaction requirements and nominated seal
- Road reserve width
- Road carriageway width (between kerb inverts).

17.6 Intersection and cul-de-sac details

Details shall generally include:

- All kerb types, driveways, crossings, footpaths and kerb crossings
- Street names
- Grades and vertical curves
- Contours on all finished road pavements indicating surface drainage flow
- Road chainages
- Proposed top of kerb and footpath levels
- Location of low points
- Levels at all tangent points, along crown of road and crown/high point in cul-de-sac head
- Radii sizes and tangents points
- Set out details for all horizontal curves
- A minimum of four kerb levels around kerb returns
- Location of all stormwater pipes and pits

Infrastructure Design Standard

- Land acquisitions and easements
- Scale bar
- Other services.

17.7 Drainage layout plans

Drainage layout plans shall as a minimum show:

- Limit of works to be constructed including all connections to existing work
- All proposed allotments (numbered), reserves and easements within the development
- All streets to be constructed, including proposed street names
- Existing and proposed PM and TBM
- All drains to be constructed, including stormwater treatment structures and outfall drains
- Existing surface levels at the corners of all allotments and all significant changes of grade within the allotment, or alternatively contour information of sufficient detail to show same
- Flood levels shall be shown where applicable
- Drainage pipe diameters and offsets from property boundaries to pipe centreline
- Drainage pit numbers
- Subsurface drains, house drains and property inlets
- All existing fences, buildings, trees, etc, on the street alignment or land through which drains or flow paths shall pass
- Existing or proposed open earth drains, dams, watercourses, bore holes, sink holes, wells and springs within the area
- Existing dams and water course, boreholes, sink holes, wells and springs within the area.

17.8 Drainage longitudinal sections

A drainage longitudinal section for each leg of drainage shall be plotted regardless of the length of the leg. Drainage longitudinal sections shall as a minimum show:

- Centreline chainage
- Existing and finished surface levels at 20m spacing maximum, and at all grade changes
- Invert level of pipe at the inlet and outlet to pits
- Datum level
- Pit description
- Depth to invert of pits from finished surface
- Pipe size, grade, class and material
- Actual velocities, actual discharge and pipe capacity
- Plot of design pipe
- Plot of hydraulic grade lines and levels

Infrastructure Design Standard

- Pit numbers
- All existing services shall be shown on the section where the designed pipe crosses
- A pit schedule detailing:
 - Pit number
 - Pit type
 - Internal dimension of pits
 - Inlet and outlet levels
 - Pipe sizes
 - Finished top of pit level
 - Depth of pit
 - Pit lid detail
 - Comments specific to pit
- The location of the pipe (ie., Street name, reserve, lot number) on the longitudinal section
- The location and type of special backfill in trenches
- Street names relevant to road crossings.

17.9 Drainage detention and treatment drawings

On-site detention and drainage detention drawings shall as a minimum show:

- Limit of works to be constructed including all connections to existing and proposed work
- Property boundaries and easements within the limit of works
- Areas of fill greater than 300mm depth
- Existing and proposed PM and TBM
- Flood levels shall be shown where applicable
- Drainage pipe diameters and grades
- Drainage pit numbers
- All existing or proposed fences, buildings, trees, public open space features in the vicinity of the works
- Invert levels of all inlet and outfall structures including pipes and open drains
- Surface levels and freeboard
- Batter slopes and grades of basin floor
- Orifice plate details or similar for on-site detention systems
- Top water levels during both the minor storm event and 100 ARI storm event
- The hydraulic grade line in the inlet pipe/drain for both the minor storm event and 100 ARI storm event
- Invert levels and cover levels of associated pits and litter traps
- Design catchment and storage volume requirements shall be stated on the plans
- Planting schedules for wetlands including quantity and species of all plantings.

Infrastructure Design Standard

17.10 Detail drawings

Detail drawings shall as a minimum show:

- Structural details of retaining walls
- All special drainage structures
- Method of downstream erosion control at headwalls
- Method of erosion control for batters in areas susceptible to erosion
- Structural pits, switching mechanisms, operating levels and pump details for pump stations
- Structural details of any estate entrance structures
- Details of street furniture.

17.11 Landscape plans

Landscape plans shall as a minimum show:

- Planting schedules and any specific planting requirements such as size of hole, root barriers, fertiliser etc
- Location and spacing of all trees, shrubs and plants etc
- Location and details of any trees or vegetation to be removed
- Irrigation details including metering, backflow prevention devices, pipe diameter and materials, valve details
- Path, bollard and fencing construction details
- Street furniture and signage details including type, location and fixing requirements
- Lighting details
- Supply and installation details of playground equipment
- Open water bodies to cross reference to other detention basin or drainage plans
- Details of services within landscaped areas.

17.12 Master services plans

Master services plans shall as a minimum show:

- All services shall be represented on these plans, including as a minimum drainage, treated/potable water, raw water, sewer, telecommunications, electrical, private works
- Trench alignments of all services within the limit of works (single line representation for shared trench)
- All pits to scale and street lighting to be shown
- Any structural or mechanical protection if applicable
- Kerb alignments and kerb crossings
- Clear identification of incidents where minimum vertical or horizontal clearances are not achieved and detail of actual clearance.

Infrastructure Design Standard

18 Appendix C – Council standard drawings

DRIVEWAY CONSTRUCTION PROFILE SINGLE RESIDENTIAL DWELLING WHERE LAYBACK KERB EXISTS

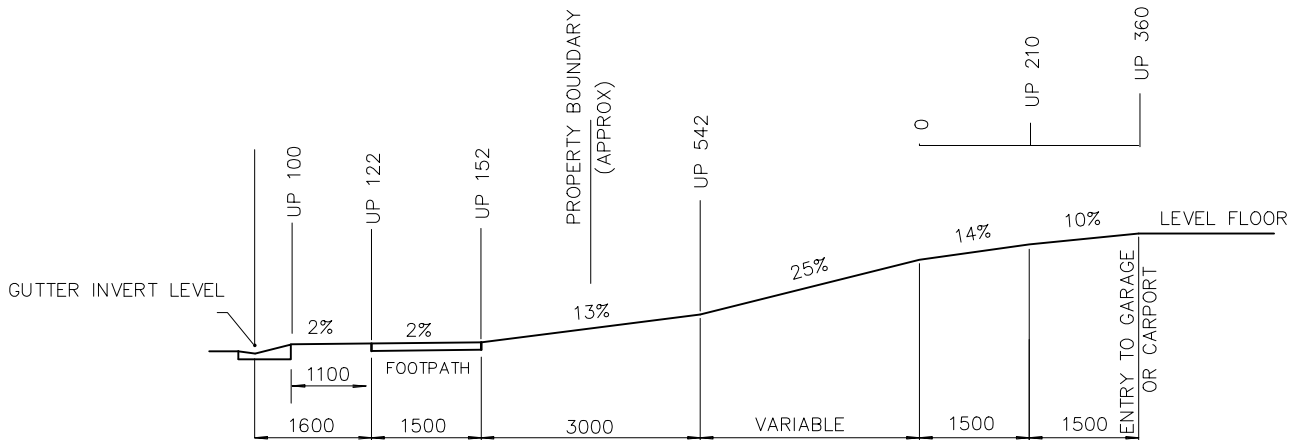

HIGH LEVEL PROFILE

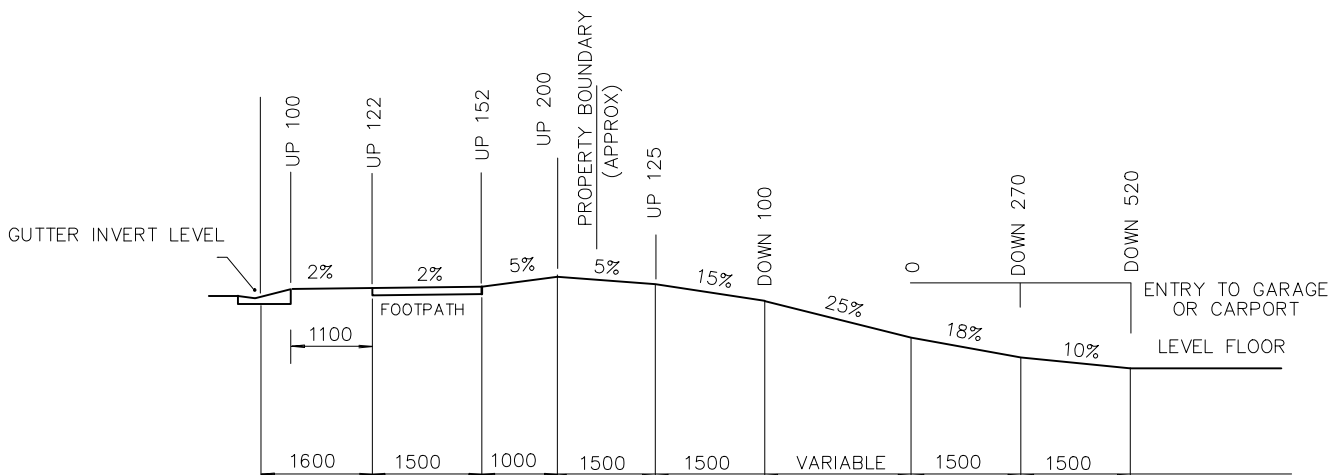

LOW LEVEL PROFILE

NOTES:

1. MEASUREMENTS SHOWN UP OR DOWN ARE MEASURED FROM THE GUTTER INVERT
 2. PRIOR TO EXCAVATIONS WITHIN THE FOOTPATH LOCATE ALL SERVICES. COUNCILS DISTRICT DEPOT IS TO BE CONTACTED FOR WATER AND SEWER. TELSTRA IS TO BE CONTACTED FOR TELECOMMUNICATION CABLES
 3. DRIVEWAY GRADES ARE TO BE ROUNDED OFF WHERE THEY MEET
 4. PROFILES SUIT MOST COMMON UNMODIFIED VEHICLES APPLICANTS SHOULD SATISFY THEMSELVES THAT THE DESIGN PROFILE WOULD MEET THEIR REQUIREMENTS
 5. THE HEIGHT DIFFERENCE FROM THE GUTTER INVERT TO THE GARAGE FLOOR CAN BE CALCULATED USING THE FOLLOWING FORMULA
 - A. HIGH LEVEL PROFILE $(X\text{mm} - 9100) / 4 + 900$
 - B. LOW LEVEL PROFILE $(X\text{mm} - 10100) / 4 + 520$
- X IS THE DISTANCE IN MILLIMETRES FROM THE FACE OF THE KERB TO THE GARAGE ENTRANCE



Approved On Behalf Of
EUROBODALLA SHIRE COUNCIL
Original Approved by
Richard Crompton for
Design & Construction Engineer
of Roads & Recreation Services
Date 14/05/2007



EUROBODALLA SHIRE COUNCIL

Driveway Construction Profile
Single Residential Dwelling
Where Layback Kerb Exists

SD 4400

Set	Sheet
F	A-001-1

Amended

DRIVEWAY CONSTRUCTION PROFILE SINGLE RESIDENTIAL DWELLING WITH NO PROVISION FOR FOOTPATH

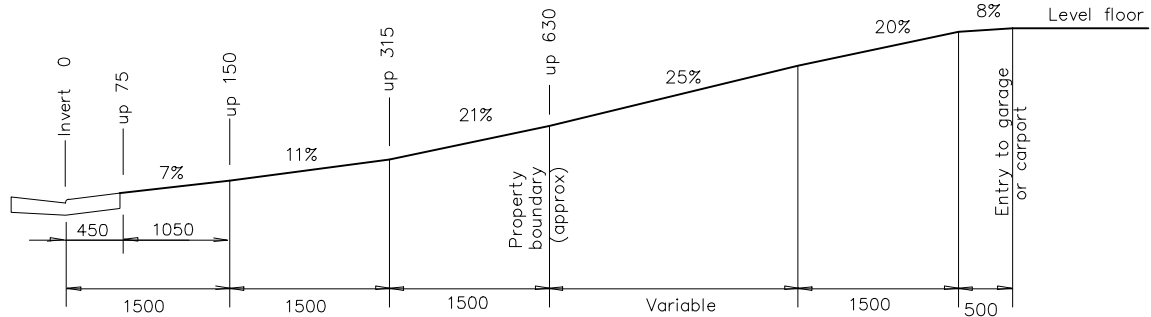

HIGH LEVEL PROFILE

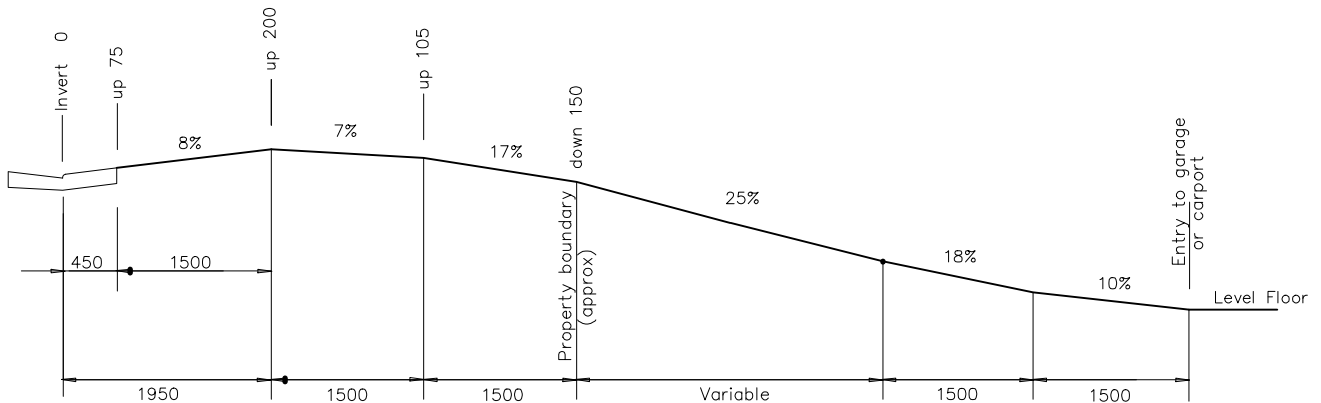

LOW LEVEL PROFILE

NOTES:

1. Measurements shown up or down, are measured from the gutter invert.
2. Prior to excavations within the footpath, locate all services. Council Depot is to be contacted for water and sewer. Telstra is to be contacted for telecommunication cables.
3. Driveway grades are to be rounded off where they meet.
4. Profiles suit most common unmodified vehicles, applicants should satisfy themselves, that the design profile would meet their requirements.
5. The height difference from the gutter invert, to the garage floor, can be calculated, using the following formula
 - A. High level profile (Xmm - 6500) / 4 + 970
 - B. Low level profile (Xmm - 7950) / 4 + 570
 X is the distance in millimeters from the face of the kerb, to the garage entrance.

 Development Engineering	Approved On Behalf Of EUROBODALLA SHIRE COUNCIL Original Approved by Richard Crompton for Design & Construction Engineer of Roads & recreation Services Date <u>27 / 06 / 2007</u>	 EUROBODALLA SHIRE COUNCIL <i>Good Government, better living</i>	EUROBODALLA SHIRE COUNCIL Driveway Construction Across Kerb and Gutter	SD 4400
				Set F Sheet A-002-1

ACCESS CONSTRUCTION OVER ROAD TABLE DRAIN

RURAL/RESIDENTIAL DISH DRAIN

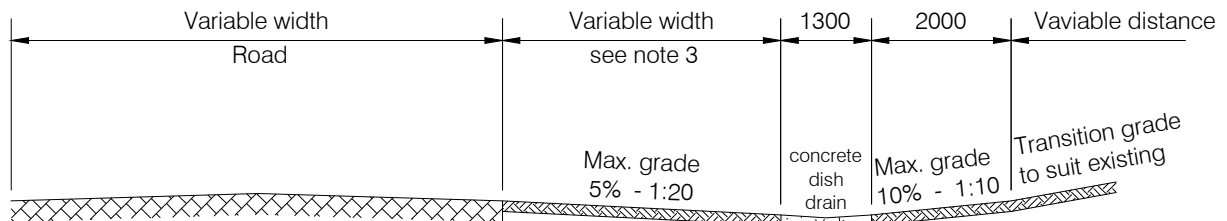
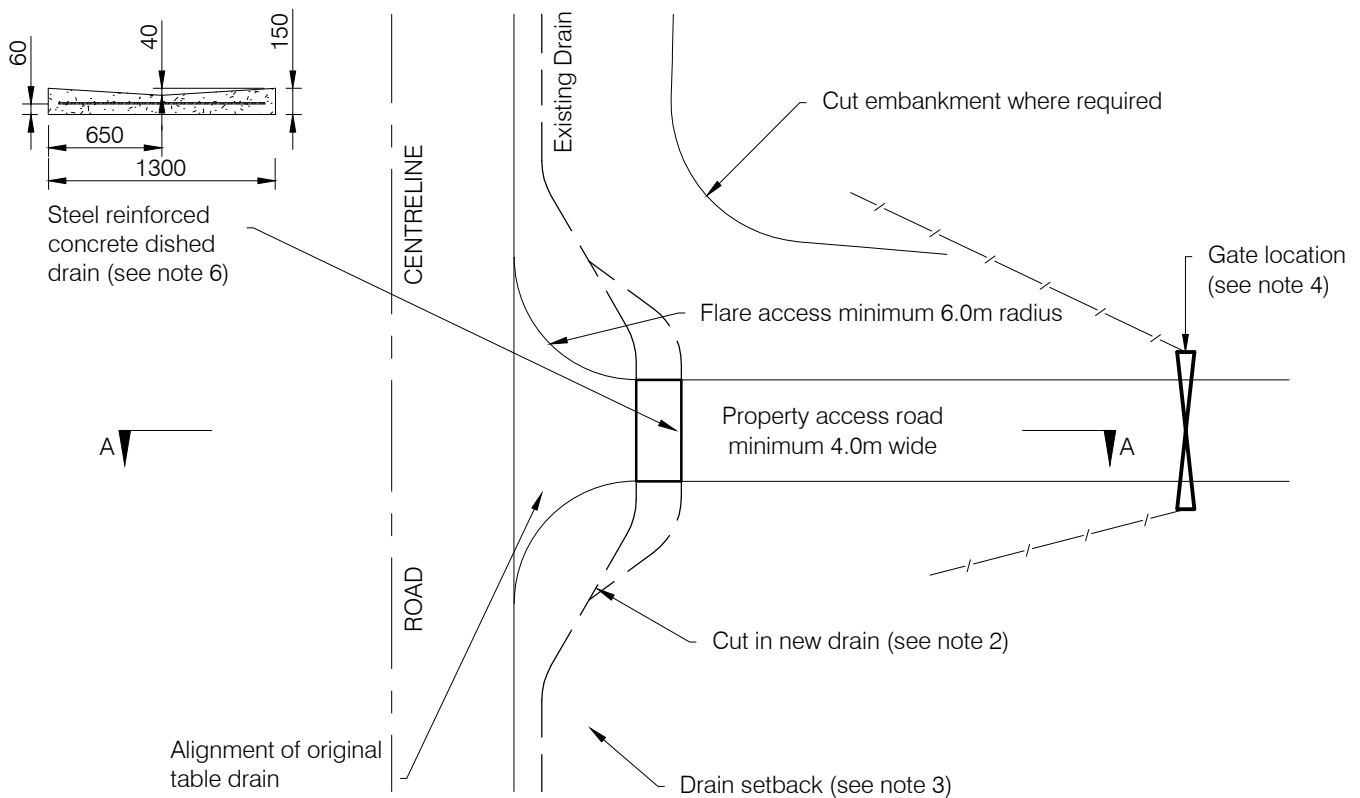

Typical Cross Section AA

NOTES:

1. An approval from Council is to be obtained prior to any construction.
2. Drain invert level to match invert level of original drain or tail out to drain invert downstream.
3. The distance from the road edge to the driveway low point is to be sufficient to provide a grade no steeper than 1:10 and comply with item 2 above.
4. In rural areas, gate construction is to provide sufficient standing area to allow a 12.5m truck to stand at the gate and be clear of the traffic.
5. The surface of the driveway is to be sealed from the edge of road to the property boundary or a minimum of 2metres past the low point which ever is the further.
6. Concrete to be a minimum of 25 MPA with F72 steel mesh minimum 60mm cover.
7. Where construction conforming to this specification cannot be achieved a piped drainage crossing would be required.

All dimensions in mm unless otherwise stated
Not to Scale

 <p>Development Engineering</p>	<p>Approved On Behalf Of EUROBODALLA SHIRE COUNCIL</p> <p>Original Approved by Richard Crompton for</p> <p>Design & Construction Engineer of Roads & recreation Services</p> <p>Date 10 / 09 / 2004</p>	 <p>EUROBODALLA SHIRE COUNCIL</p> <p>Good Government, better living</p>	<p>EUROBODALLA SHIRE COUNCIL</p>	<p>SD 4400</p>
	<p>Access Construction Over Road Table Drains Rural/Residential Dish Drain</p>		<p>Set F Sheet A-010-1</p>	
			<p>Amend.</p>	

ACCESS CONSTRUCTION OVER ROAD TABLE DRAIN

RURAL PIPED CROSSING

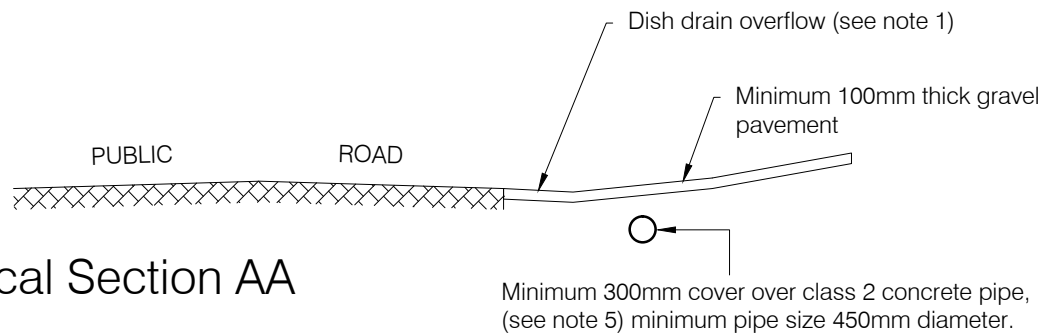
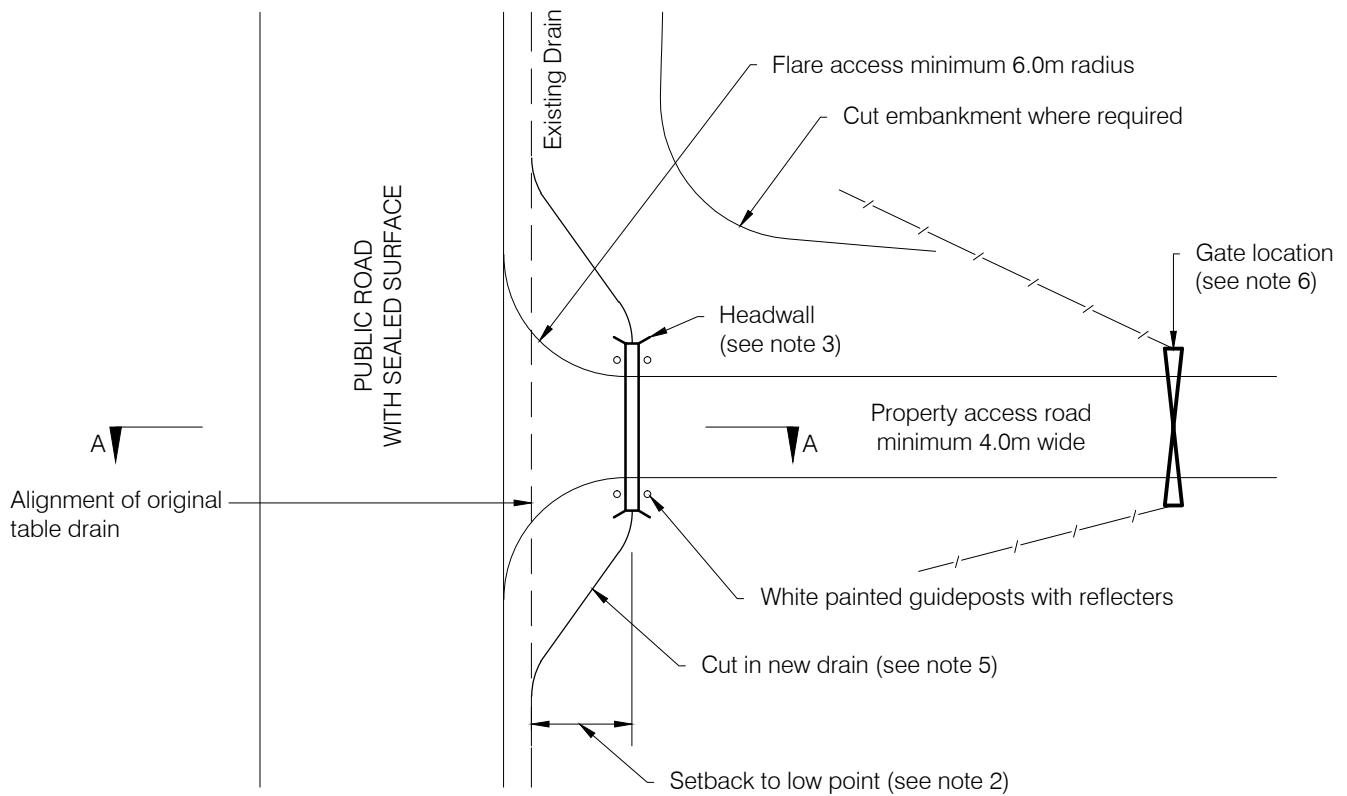

Typical Section AA

NOTES:

1. Access construction is to allow for an overflow, which will not direct water over public road surface, should pipe blockage occur.
2. Pipe setback may be required, to allow flared access and drainage overflow.
3. Headwall to be of concrete construction.
4. Pipe length Minimum 3.6m (Recommended 4.8m)
5. Pipe invert to match invert level of original drain.
6. Gate location is to provide sufficient standing area, to allow a 12.5m truck to stand at the gate and be clear of the traffic.
7. Rural driveways, where road seal exists. are to provide a sealed driveway from the road, to at least the property boundary.

All dimensions in mm unless otherwise stated
Not to Scale



Approved On Behalf Of
EUROBODALLA SHIRE COUNCIL
Original Approved by
Richard Crompton for
Design & Construction Engineer
of Roads & recreation Services
Date 05 / 07 / 2005



EUROBODALLA SHIRE COUNCIL

Access Construction Over Road Table Drains
Rural Piped Crossing

SD 4400

Set	Sheet
F	A-011-1
Amended	

DRIVEWAY CONSTRUCTION ACROSS KERB LINE

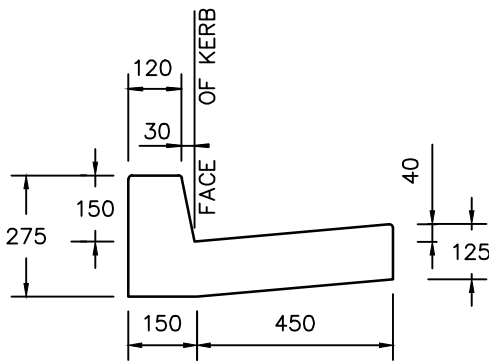
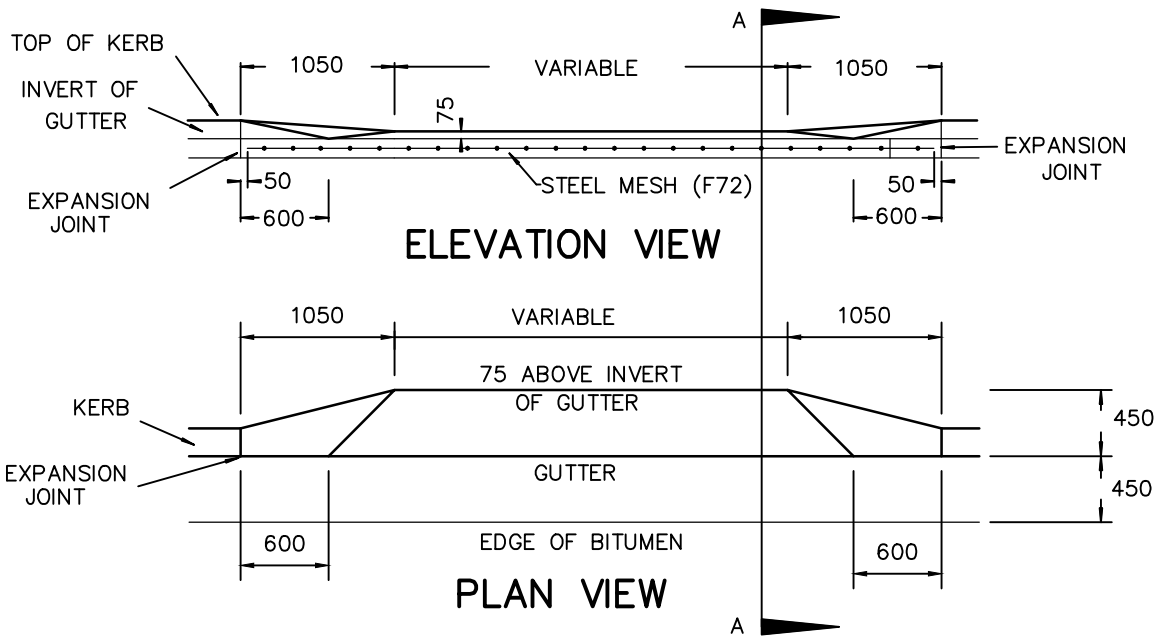

KERB & GUTTER

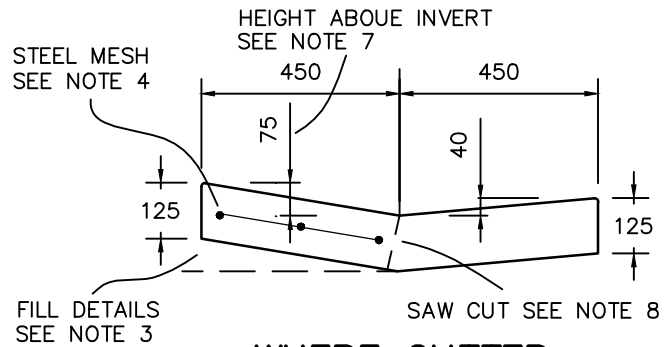

WHERE GUTTER IS TO BE MAINTAINED

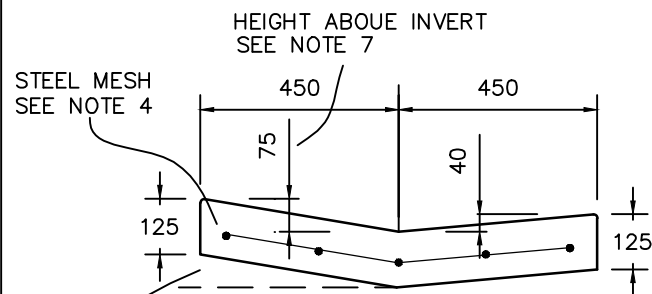

WHERE KERB & GUTTER IS TO BE REMOVED

General Notes:

1. Concrete to be 25Mpa.
2. Any access construction requires council approval.
3. Any excavation in this area is to be backfilled with concrete or fully compacted granular fill.
4. Steel reinforcement is to be A.S. F72 mesh 60mm from bottom of concrete. 50mm cover at ends.
5. Where the gutter is in poor condition it is to be replaced.
6. Height of layback may be varied from 50 mm to 100mm where approved by council.
7. Dimensions in millimeters.
8. Kerb is to be saw cut 5mm up from invert, removed and replaced in accordance with this plan.
9. Where the gutter is in poor condition it is to be replaced.
10. Where kerb and gutter is to be replaced, the road pavement and seal is to be restored to the satisfaction of council.



Approved On Behalf Of
EUROBODALLA SHIRE COUNCIL
Original Approved by
Richard Crompton for
Design & Construction Engineer
of Roads & recreation Services
Date 27 / 06 / 2008



EUROBODALLA SHIRE COUNCIL

Driveway Construction
Across Kerb and Gutter

Plan	4400-A
No.	001-b-1
Amend.	12/3/09

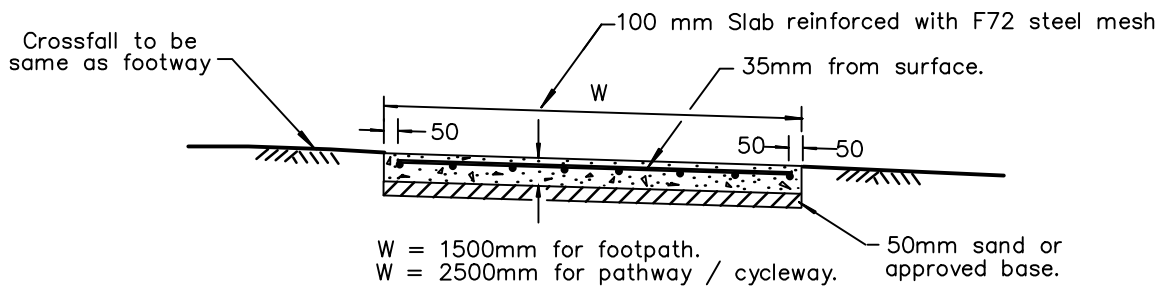

TYPICAL SECTION OF PATHWAY

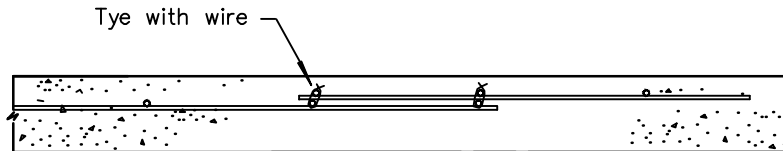

JOINING MESH

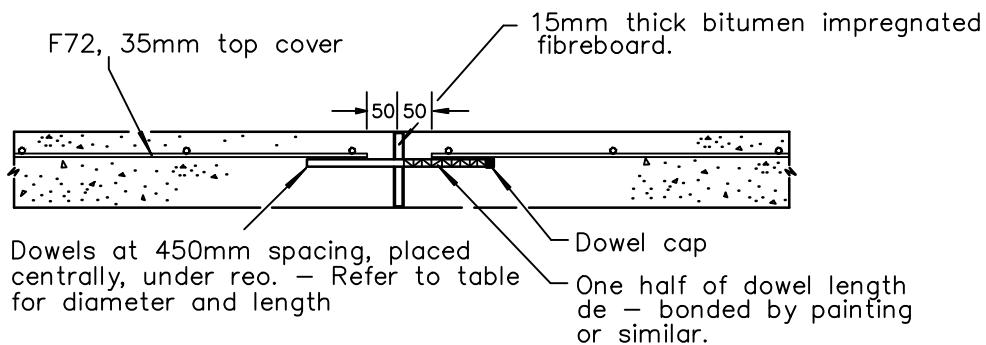

EXPANSION JOINT

DOWEL DIMENSIONS

Slab thickness	Dowel Dia	Dowel length
100mm	R12 bars Gal.	400mm

3 and 4 dowels for footpaths and cycleways respectively.

NOTES:

- Compressive Strength of concrete at 28 Days to be minimum 25 MPa.
- All pathways to be broom finished, then all exposed using an edging tool.
- Joint Spacing : Expansion Joint – 18m max interval
Contraction joints at 3.6m intervals
- Crossfall – 1 to 2.5%
- Proprietary types of expansion joints may be used with ESC supervisors approval.
- Concrete footpaths, adjoining driveways are to be transitioned over a 5.0m length.
- A Street opening permit must be obtained from Council, seek approval of location and levels prior to excavation.



Approved On Behalf Of
EUROBODALLA SHIRE COUNCIL
Original Approved by
Richard Crompton for
Design & Construction Engineer
of Roads & recreation Services
Date 27 / 11 / 2008



EUROBODALLA SHIRE COUNCIL

Construction Specification
Footpath Detail

Plan	4400-A
No.	002-a-2
Amend.	25/06/2010

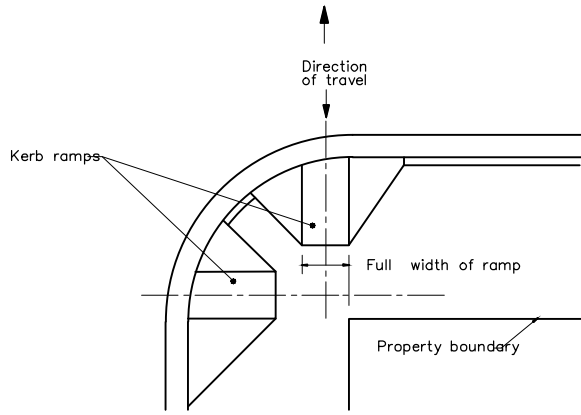

LOCATION OF KERB RAMPS

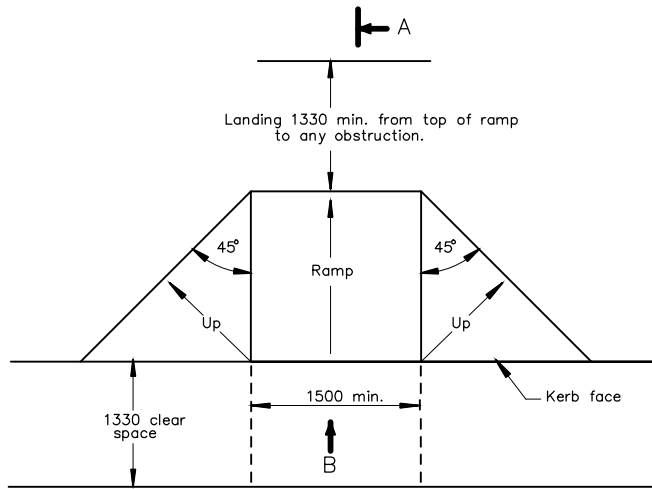

PLAN A

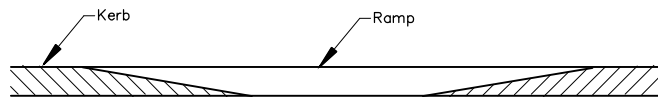

ELEVATION B

Include angle between ramp surface and roadway or lower surface
166° min.

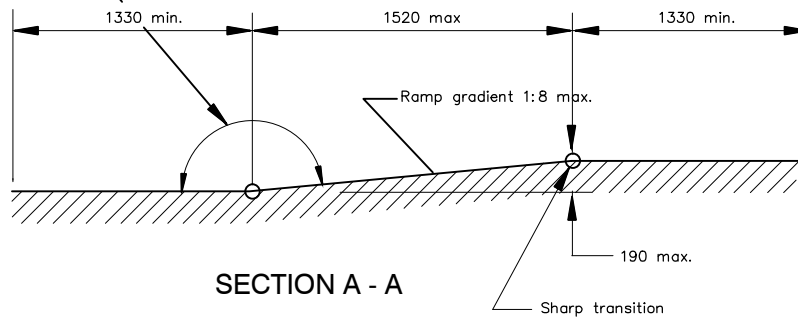

SECTION A - A



Approved On Behalf Of
EUROBODALLA SHIRE COUNCIL
Original Approved by
Richard Crompton for
Design & Construction Engineer
of Roads & recreation Services
Date 07 / 10 / 2005



EUROBODALLA SHIRE COUNCIL

Construction Specification
Kerb and Step Ramps

Plan	4400-A
No.	003-a-1
Amend.	16/3/09

Notes

Refer to AS1428Pt1-2001 and AS1428Pt4-2002 for additional details and compliance as necessary.

Ramp surface to be non-slip finish and/or to equal adjoining path finish. Wing surface finish to be contrasting rougher wood trowel cove or similar finish. Refer to Plan 4400 - Footpath Detail, Notes 1 & 2 for concrete specifications.

Tactile Ground Surface Indicator's (TGI's) to be vitrified porcelain tiles or equal. Stick on TGI's are considered inappropriate for outdoor areas. Ensure colour selection and other material characteristics comply with AS 1428pt4.

TGI's should be installed where a high pedestrian use is expected. This includes within CBD's, near schools and other public buildings and where determined by Council at DA assessment.

See also Specification 4400-A-003-c-1 "Kerb and Step Ramps Path of Travel Alignment" and Specification 4400-A-003-a-1 "Kerb and Step Ramps".

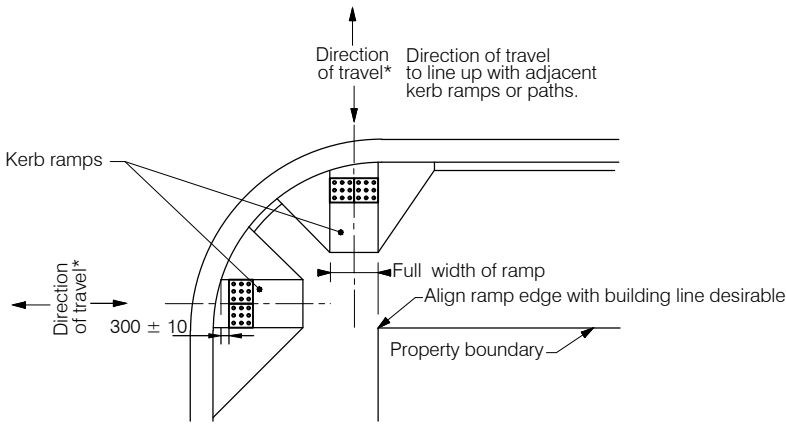

LOCATION OF KERB RAMP

Where 45° is not achievable (wing gradient steeper than 1 in 8), consideration should be given to protect or remove wing using devices such as bollards or planter boxes.

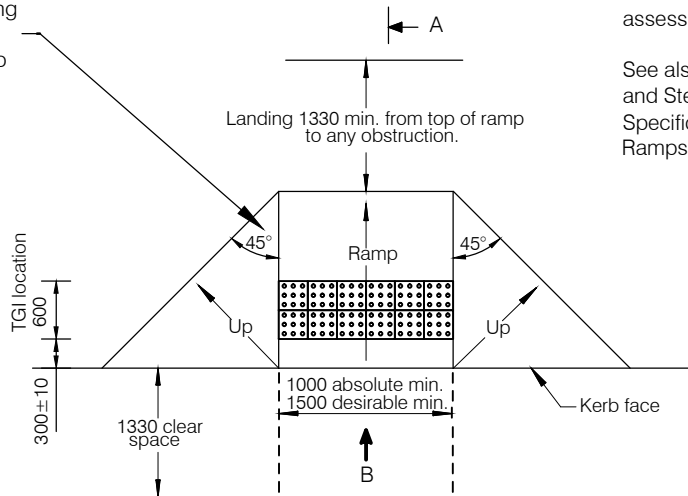

PLAN

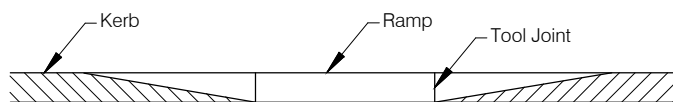

ELEVATION B

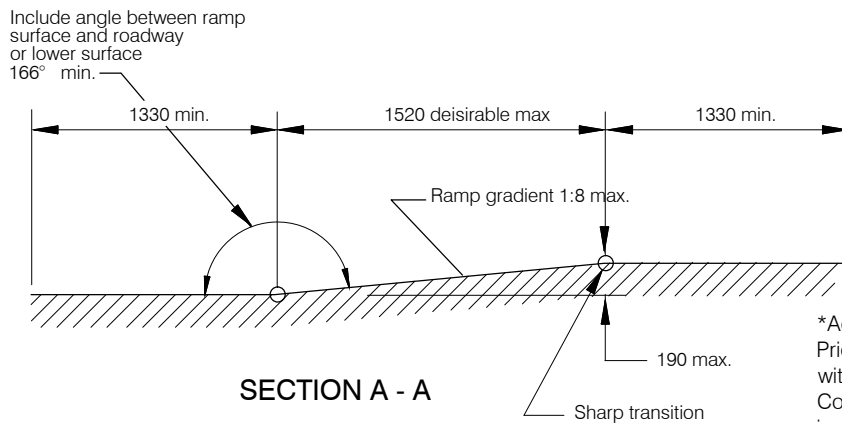

SECTION A - A

*Advice:
Prior to construction check with Eurobodalla Shire Council to ensure specification is current.

All dimensions in mm
Not to Scale

	Approved On Behalf Of EUROBODALLA SHIRE COUNCIL Original Approved by Richard Crompton for Design & Construction Engineer of Roads & recreation Services Date 10 / 07 / 2009	 EUROBODALLA SHIRE COUNCIL Good Government. better living	EUROBODALLA SHIRE COUNCIL		
	Construction Specification Kerb and Step Ramps with Tactile Indicators		Plan	4400-A	
			No.	003-b	
			Amend.		

Notes

A. Wing angle desirable 45°. Where no pedestrian traffic is expected it may be reduced to 30°.

B. Distance invert of kerb to front of tactile is desirable 300 (at centre of ramp). Where configuration dictates, this may be exceeded and the distance at the ramp edge to invert shall be a minimum 150.

C. Refer to AS1428Pt1-2001 and AS1428Pt4-2002 for additional details and compliance as necessary.

D. Ramp surface to be non-slip finish and/or to equal adjoining path finish. Wing surface finish to be contrasting rougher wood trowel cove or similar finish. Refer to Plan 4400 - Footpath Detail, Notes 1 & 2 for concrete specifications.

E. Tactile Ground Surface Indicator's (TGI's) where required to be vitrified porcelain tiles or equal. Stick on TGI's are considered inappropriate for outdoor areas. Ensure colour selection and other material characteristics comply with AS 1428pt4.

F. TGI's should be installed where a high pedestrian use is expected. This includes within CBD's, near schools and other public buildings and where determined by Council at DA assessment.

G. See also Specification 4400-A-003-b-1 "Kerb and Step Ramps with Tactile Indicators" and Specification 4400-B-003-a-1 "Kerb and Step Ramps".

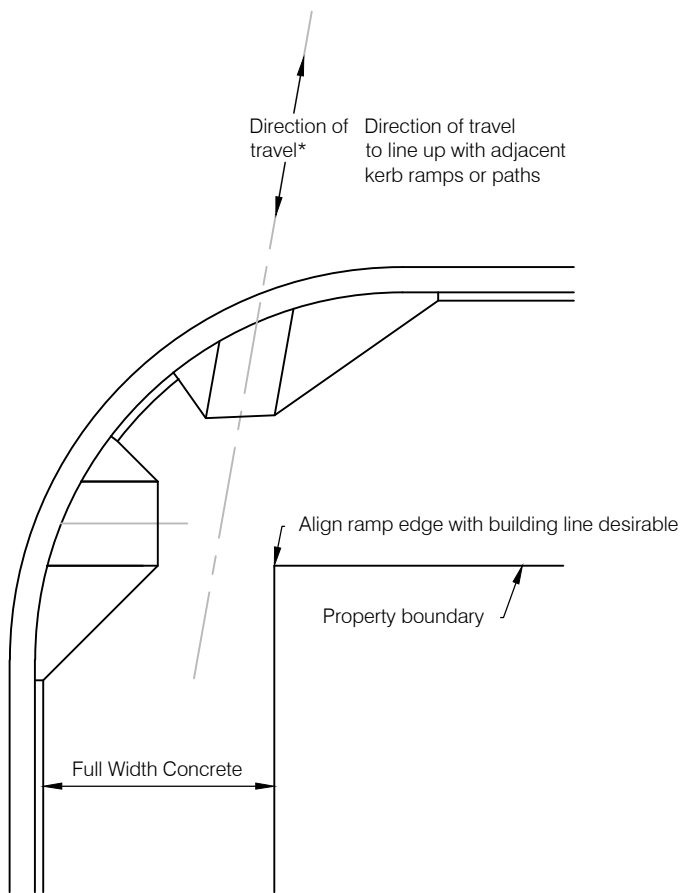
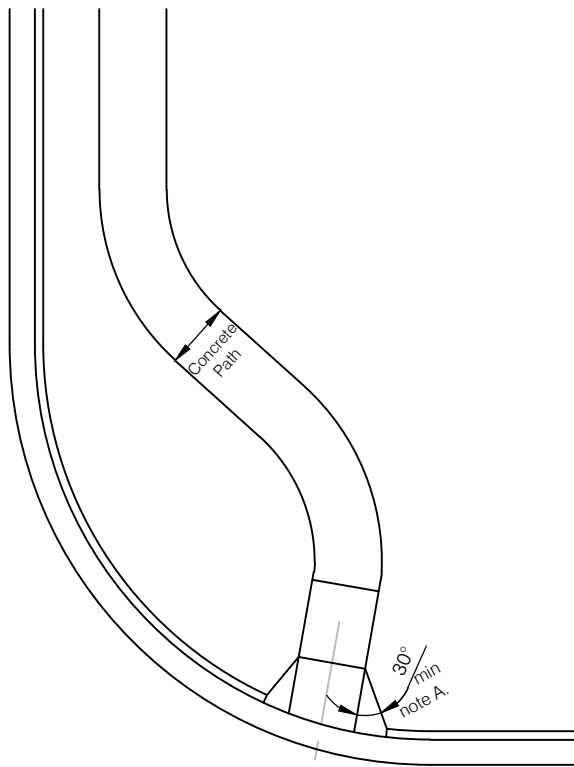

LOCATION OF KERB RAMPS

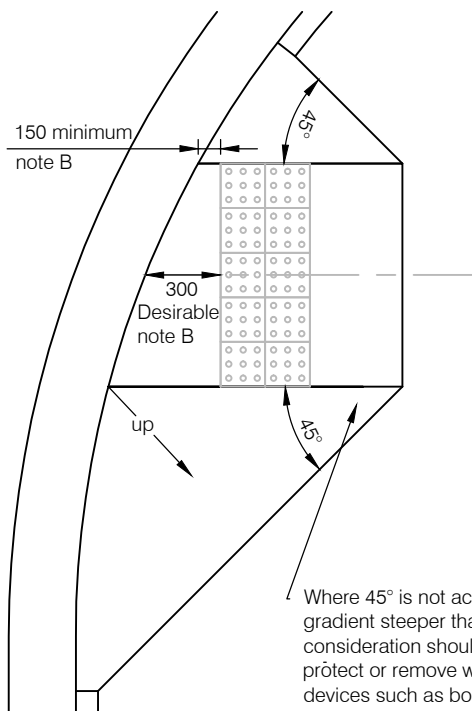

DETAIL

All dimensions in mm
Not to Scale

	Approved On Behalf Of EUROBODALLA SHIRE COUNCIL Original Approved by Richard Crompton for Design & Construction Engineer of Roads & recreation Services Date 14 / 10 / 2009	 EUROBODALLA SHIRE COUNCIL Good Government, better living	EUROBODALLA SHIRE COUNCIL		
	Construction Specification Kerb and Step Ramps Path of Travel Alignment		Plan 4400-A	No. 003-c	
			Amend.		

Pipe Bedding Support - Trafficable Areas

Notes:

Trench Width is to be Adequate for Proper Compaction of Side Walls.

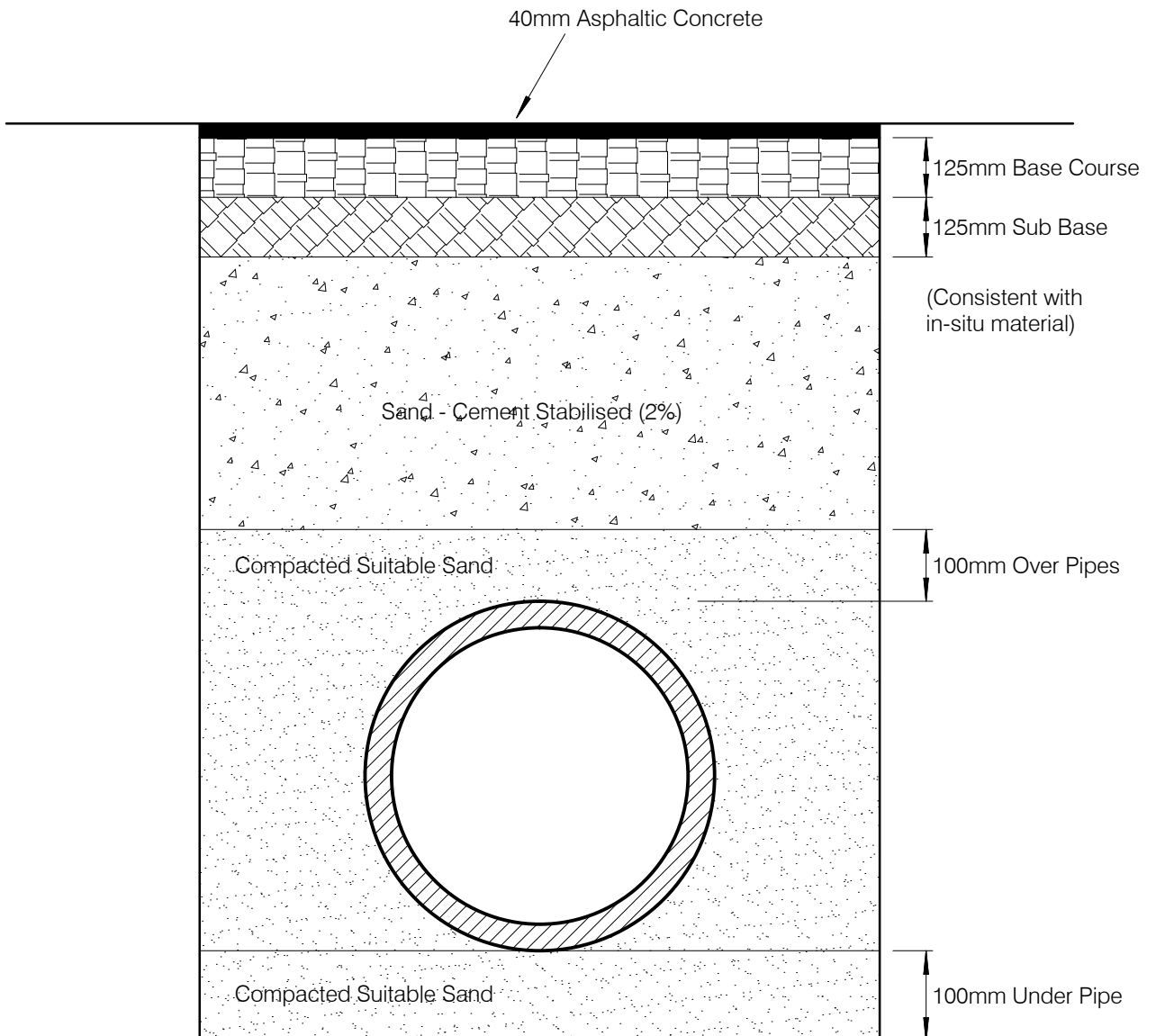

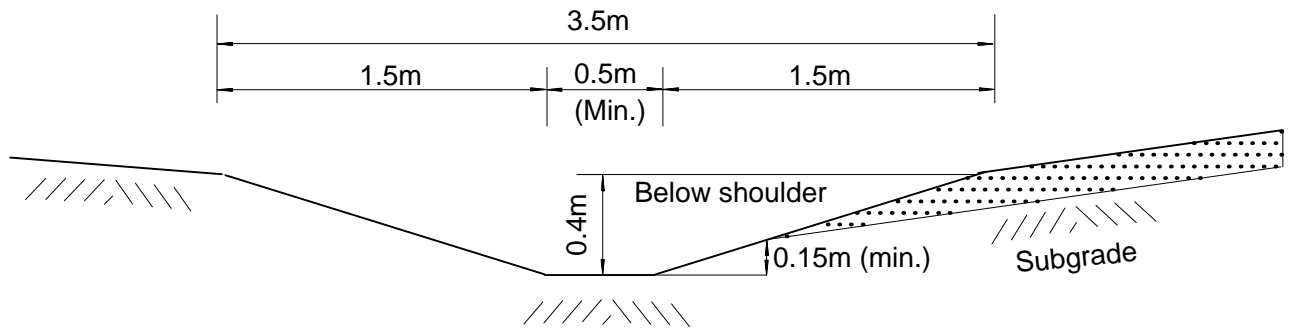

TYPICAL TABLE DRAIN SECTION

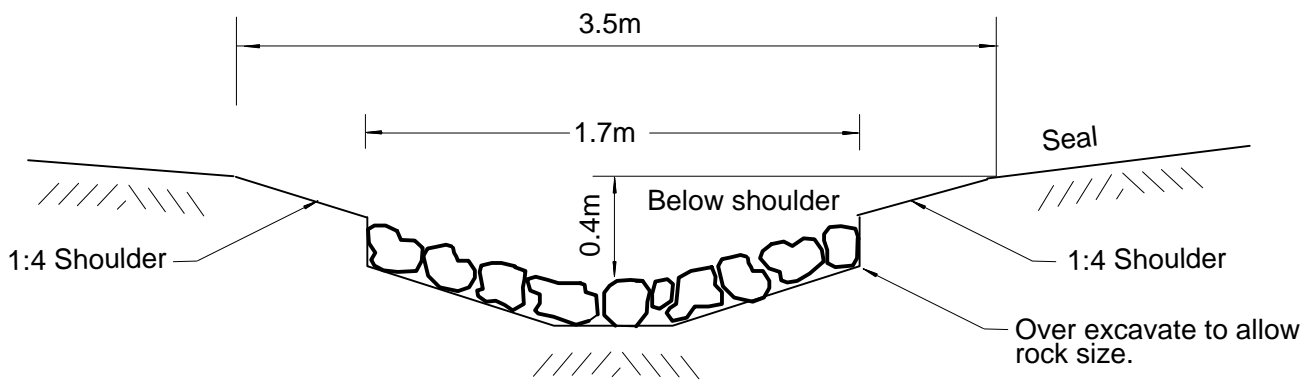

ROCK LINED DRAIN SECTION

NOTE:

Use a graded rock, generally 200mm gabian rock, for most jobs.

For large water volumes. the drain profile is to be enlarged, to cater for the larger rock size.

Rock lined table drains are not permitted for Council infrastructure.



Approved On Behalf Of
EUROBODALLA SHIRE COUNCIL
Original Approved by
Richard Crompton for
Design & Construction Engineer
of Roads & recreation Services
Date 26 / 06 / 2007



EUROBODALLA SHIRE COUNCIL

Construction Specification
Rock Lined Drains

SD 4400

Set	C-008-1
-----	---------

Amended

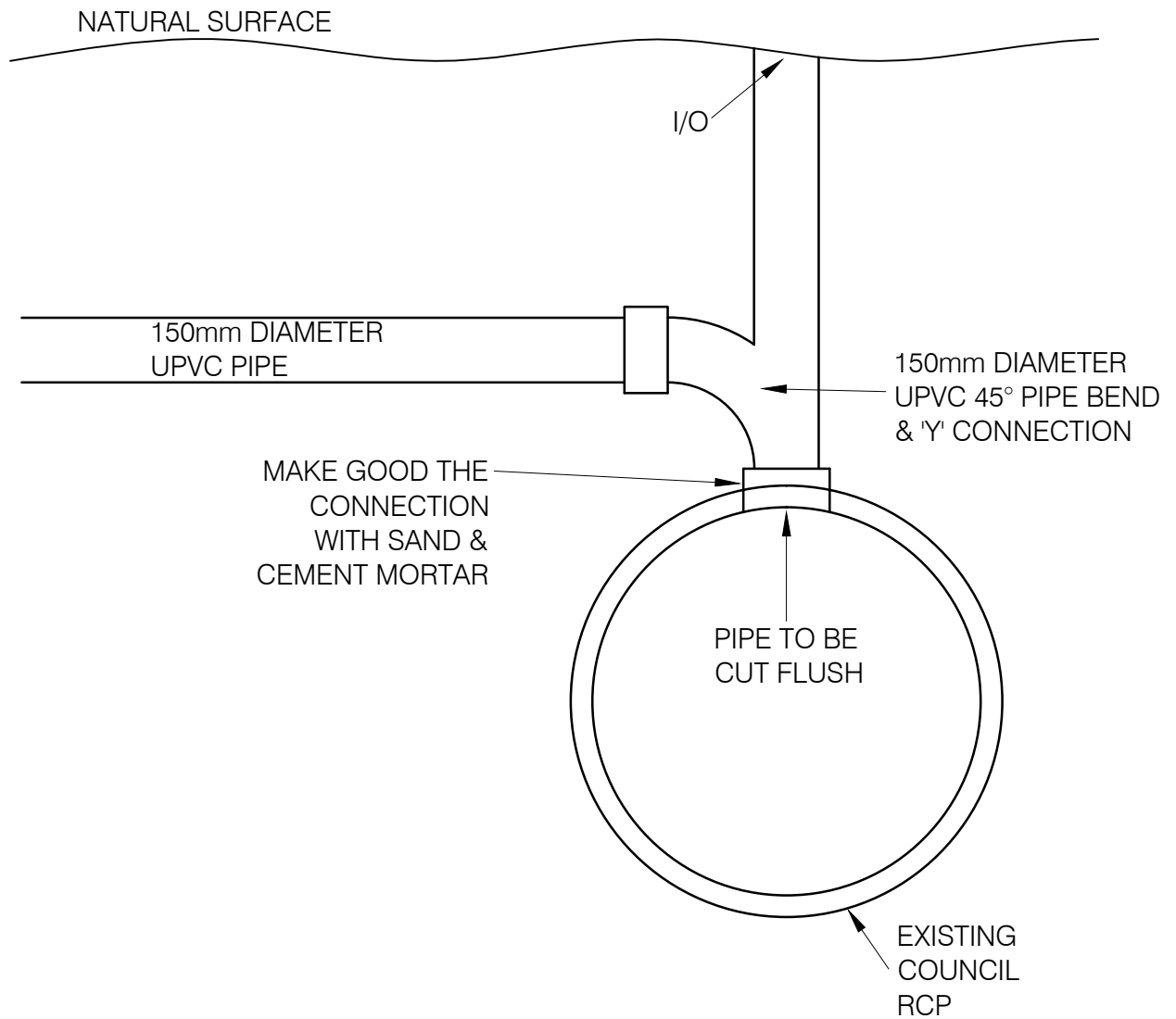

NOTES:

1. DRAWINGS ARE NOT TO SCALE & INDICATIVE ONLY.
2. RCP denotes REINFORCED CONCRETE PIPE.
3. I/O denotes INSPECTION ORIFICE.
4. I/O's ARE TO BE PROVIDED FOR CLEANING & MAINTENANCE PURPOSES.
4. UPVC denotes UNPLASTICISED POLYVINYL CHLORIDE (RIGID PVC).

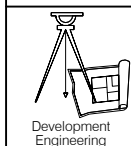

Approved On Behalf Of
EUROBODALLA SHIRE COUNCIL

Original Approved by Date
Micheal McIlveen 15/05/2015

Development Engineering Coordinator



eurobodalla shire council

STANDARD DRAWING
STORMWATER CONNECTION
TO COUNCIL'S
INFRASTRUCTURE

SD 4400

Set	Sheet
F	C-009-1

Amended

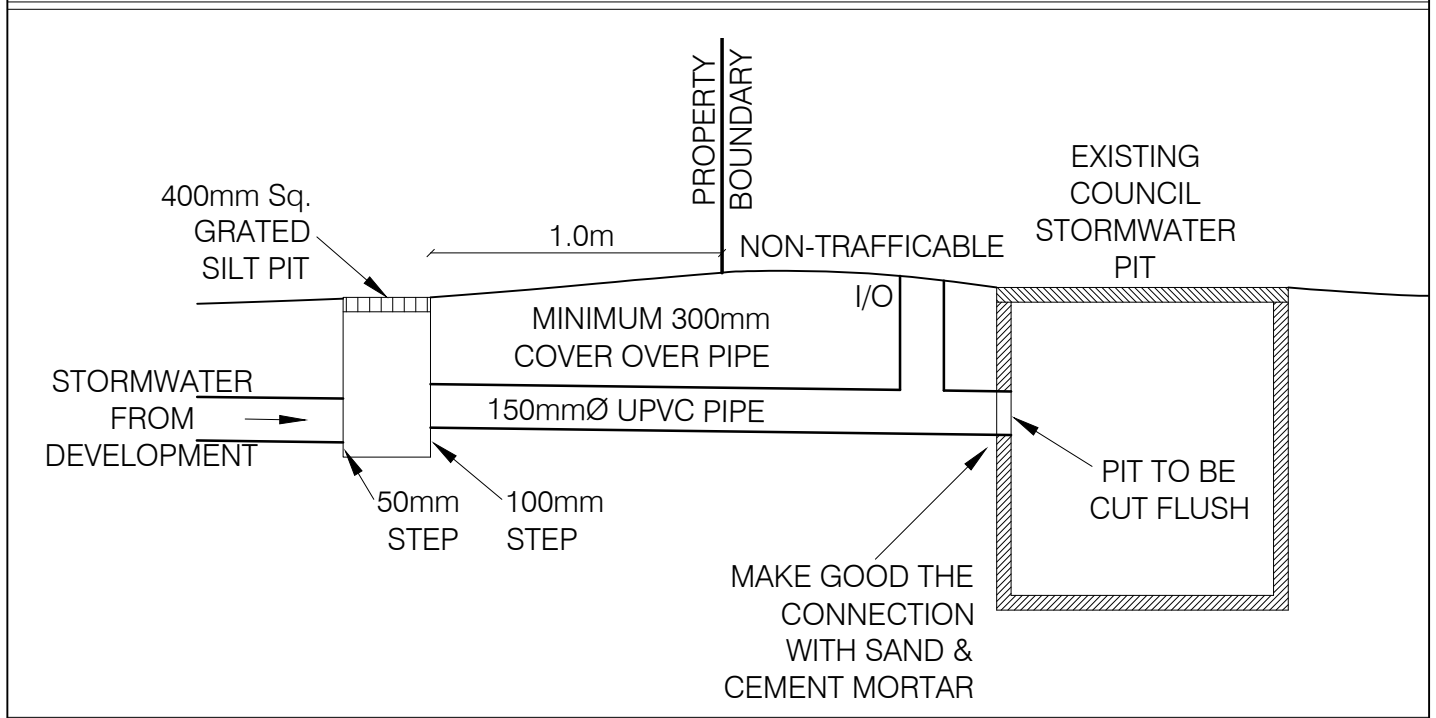
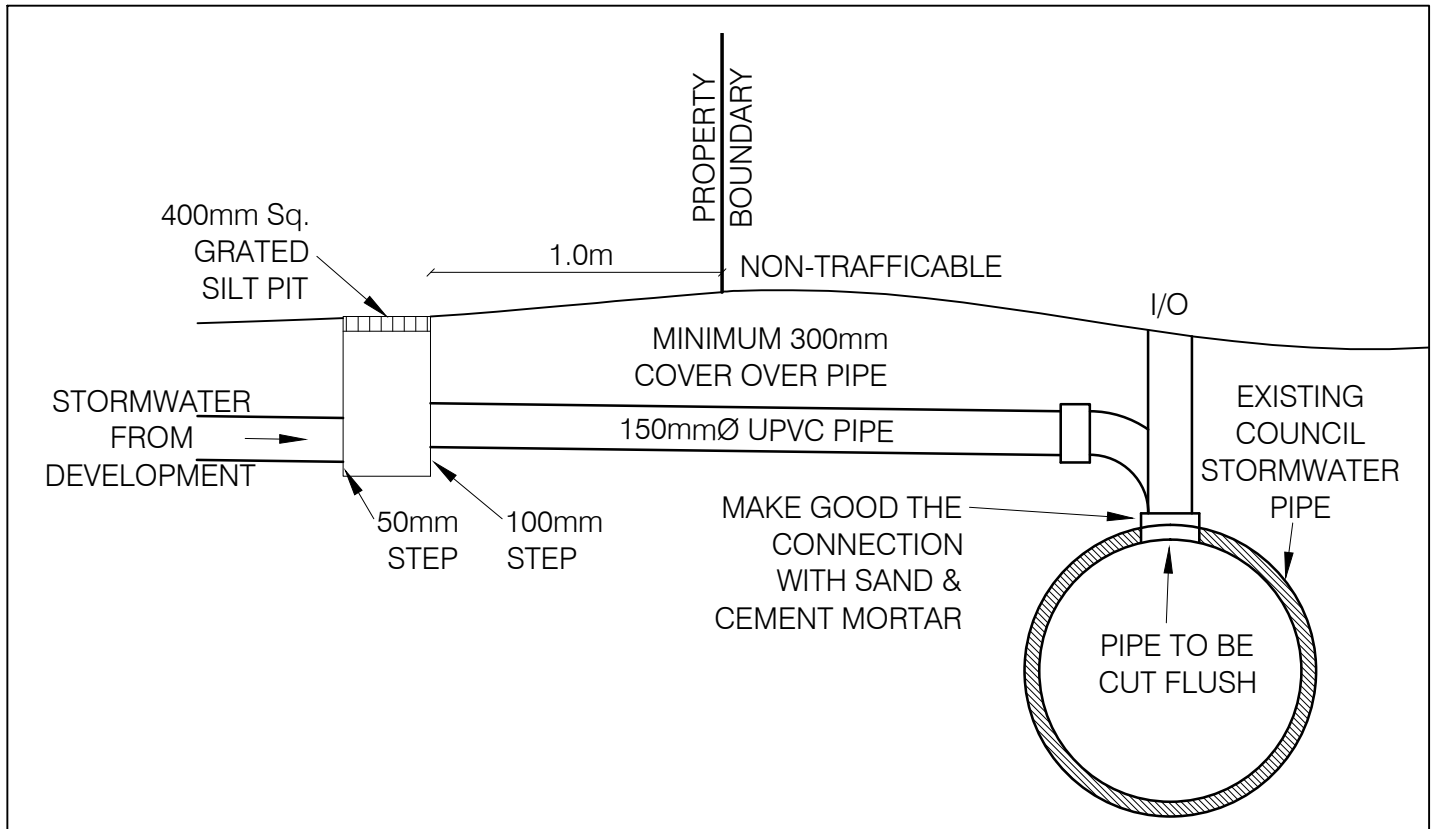

NOTES:

1. DRAWINGS ARE NOT TO SCALE & INDICATIVE ONLY.
2. ALL PIPES TO BE LAID AT MINIMUM 1% GRADE.
3. I/O DENOTES INSPECTION ORIFICE.

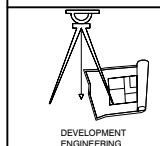

Approved On Behalf Of
EUROBODALLA SHIRE COUNCIL

Micheal McIvreen
Development Engineering
Coordinator

Date 30/6/2014



EUROBODALLA SHIRE COUNCIL

HOUSE DRAINAGE
CONNECTION LAYOUT

SD 4400	
Set F	Sheet C-010-1
Amended	

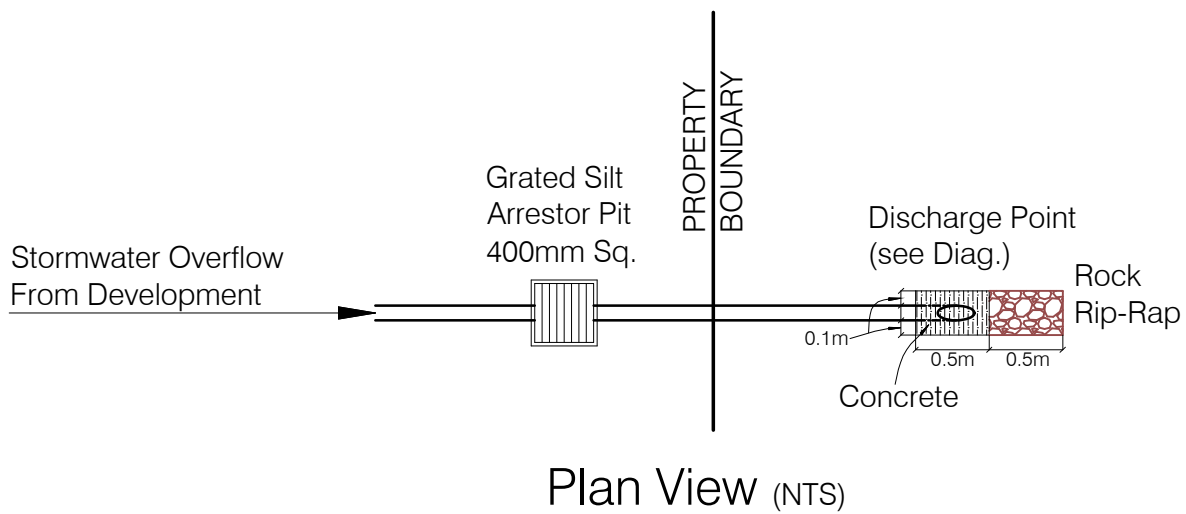
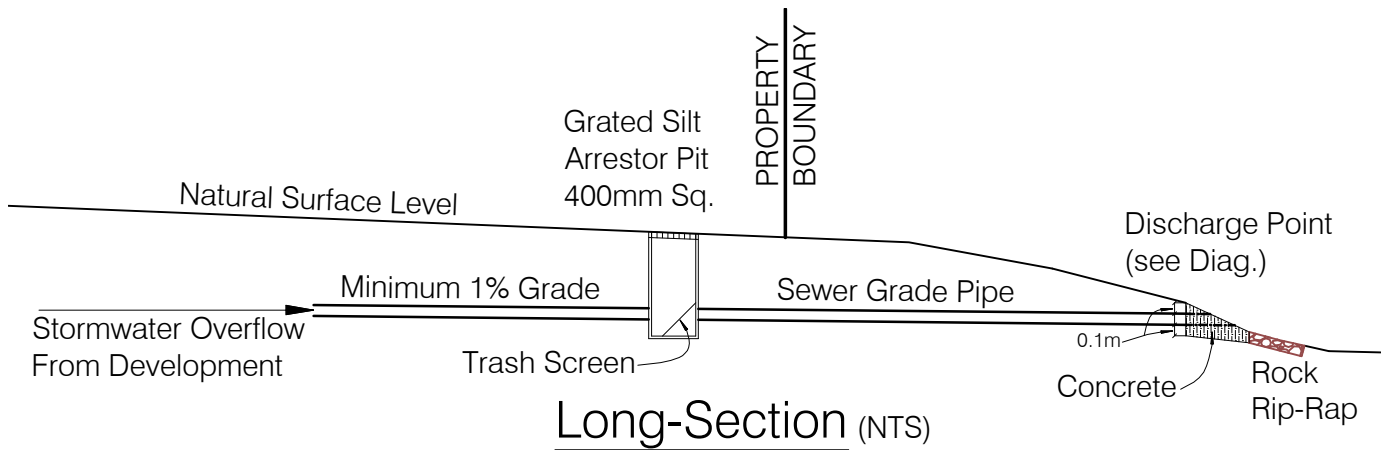

NOTES:

1. DRAWINGS ARE NOT TO SCALE & INDICATIVE ONLY.
2. ALL WORK IS TO BE CARRIED OUT IN ACCORDANCE WITH AS3500 & PART 3 OF THE BCA.
3. ALL WORK IS TO BE CARRIED OUT AT NO COST TO COUNCIL.
4. THE OUTLET INVERT IS TO BE A MINIMUM 100mm ABOVE THE INVERT LEVEL OF THE TABLE DRAIN.
5. BOTH THE VERGE & TABLE DRAIN PROFILES ARE TO BE MAINTAINED IN THEIR EXISTING FORMS.
6. ROCK RIPRAP IS TO CONSIST OF MINIMUM 100mm DIAMETER ROCK, IMBEDDED BELOW THE DRAIN PROFILE.
7. THE SILT ARRESTOR IS NOT REQUIRED WHERE ROOF WATER ONLY IS CONTAINED WITHIN THE PIPING.

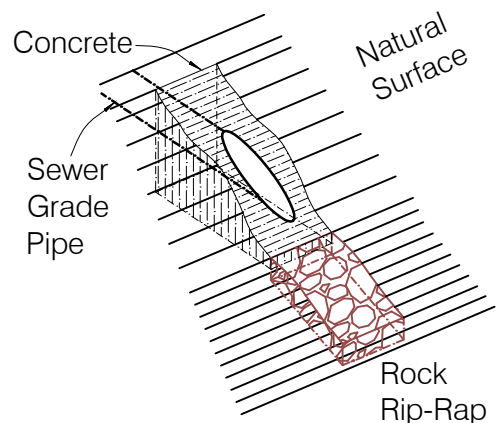

**Discharge Point
Diagram (NTS)**

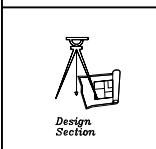

Approved On Behalf Of
EUROBODALLA SHIRE COUNCIL

Micheal McIlveen
Development Engineering
Coordinator

Date 30/6/2014



EUROBODALLA SHIRE COUNCIL

**HOUSE DRAINAGE
DISCHARGE TO OPEN DRAIN
OR SIMILAR**

SD 4400

Set F	Sheet C - 011-1
Amended	

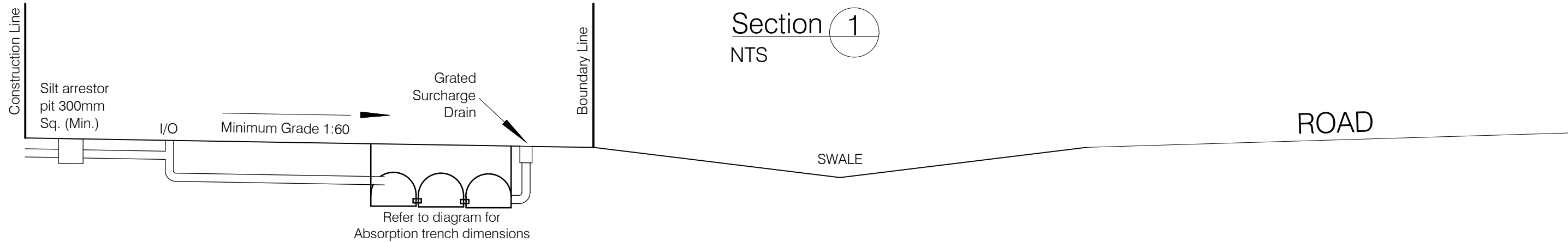

Plan View

NTS

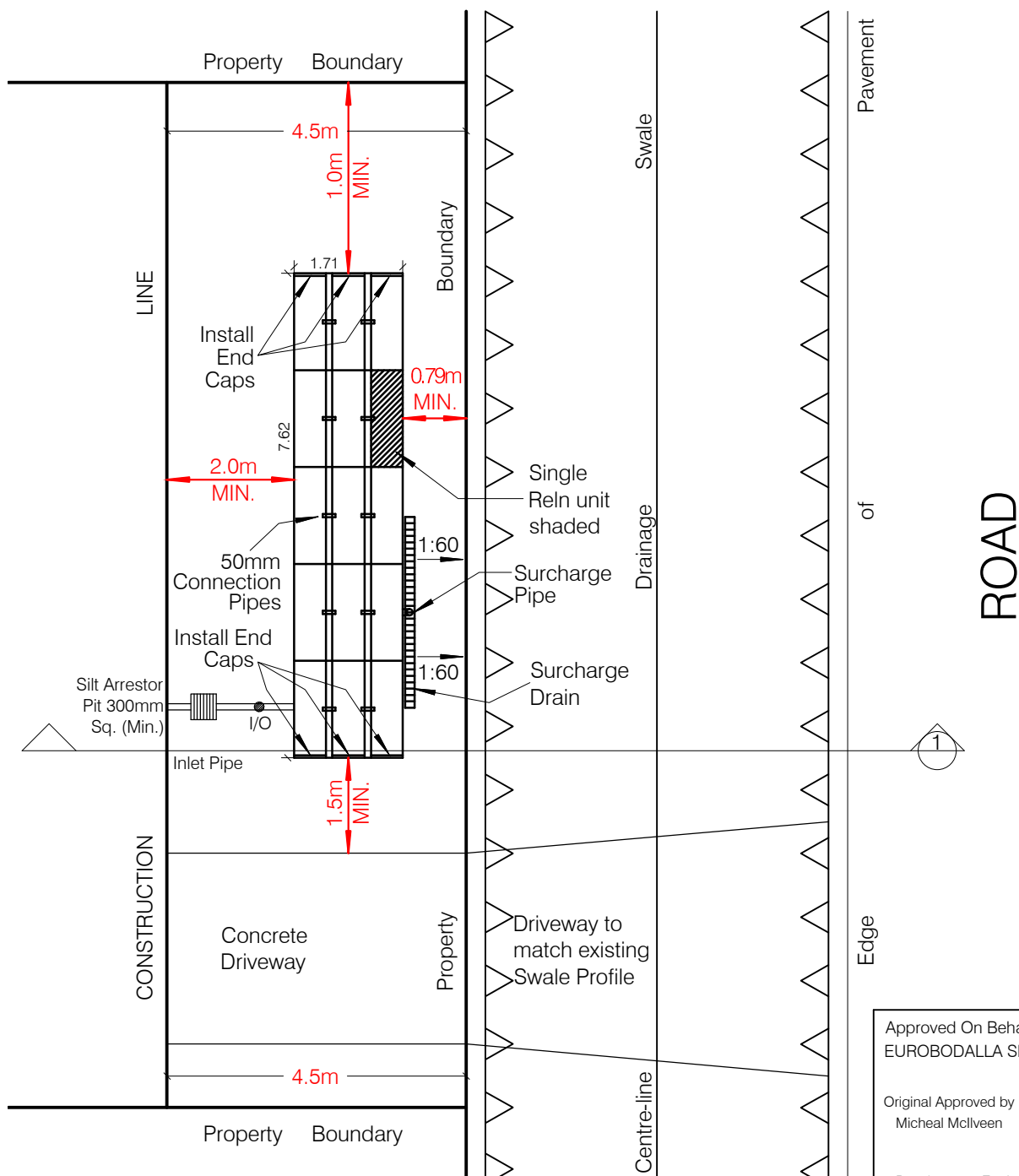

Typical Absorption Trench Configuration

N.T.S

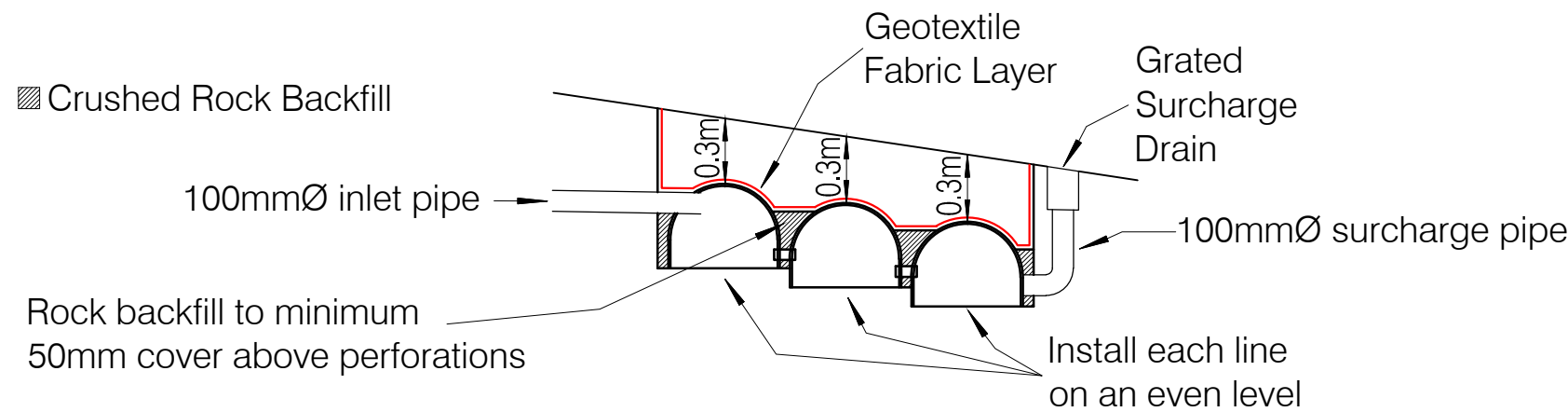

Rejn Jumbo Trench Unit

Dimensions

NTS

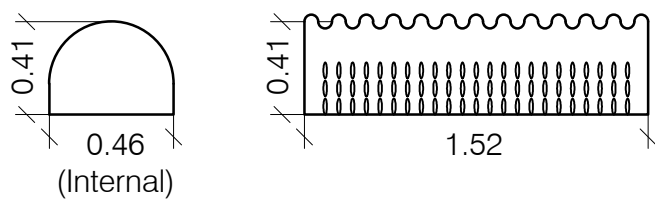

NOTES:

1. EACH LINE OF DRAINAGE UNITS IS TO BE INSTALLED ON AN EVEN LEVEL.
2. MINIMUM COVER OF 0.3m ON TOP OF STORAGE UNITS.
3. BACKFILL TO COMPLY WITH AS3500.3 (2003).
4. CRUSHED ROCK BACKFILL TO BE GRADED 20-40mm.
5. ALL PIPES AND FITTINGS TO BE CLASS SN2 100Ø PVC (UNLESS OTHERWISE SPECIFIED).
6. OVERLAND FLOW PATH TO BE MINIMUM GRADE OF 1:60 FROM THE SURCHARGE DRAIN.
7. TRENCHING MAY BE PLACED WITHIN THE DRIVEWAY SETBACK OR UNDERNEATH THE DRIVEWAY WITH THE PROVISION OF ENGINEERING CERTIFICATION FOR: DRIVEWAY STABILITY AND; INTEGRITY OF THE ABSORPTION SYSTEM.
8. THIS PLAN IS ONLY TO BE USED TO DETERMINE THE LOCATION OF AN ABSORPTION SYSTEM AND ASSOCIATED FITTINGS.
9. I/O DENOTES INSPECTION ORIFICE
10. CONSIDERATION SHOULD BE GIVEN TO THE POSSIBILITY OF VEHICLE LOADINGS ON TURFED AREAS.
11. BOUNDARY OFFSETS TO BE MINIMUM 3.0m WHEN ABSORPTION SYSTEM LOCATED AT REAR OF PROPERTY.
12. MINIMUM 2.0m OFFSET FROM CONSTRUCTION LINE FOR CLASS-A SOIL. INCREASES TO 3.0m CLASS-S & 5.0m CLASS-M

Approved On Behalf Of
EUROBODALLA SHIRE COUNCIL

Original Approved by
Micheal McIlveen

Date
15/05/2015

Development Engineering Coordinator



eurobodalla shire council

TYPICAL ABSORPTION
TRENCH LAYOUT

SD 4400

Set F	Sheet C-012-1
Amended	

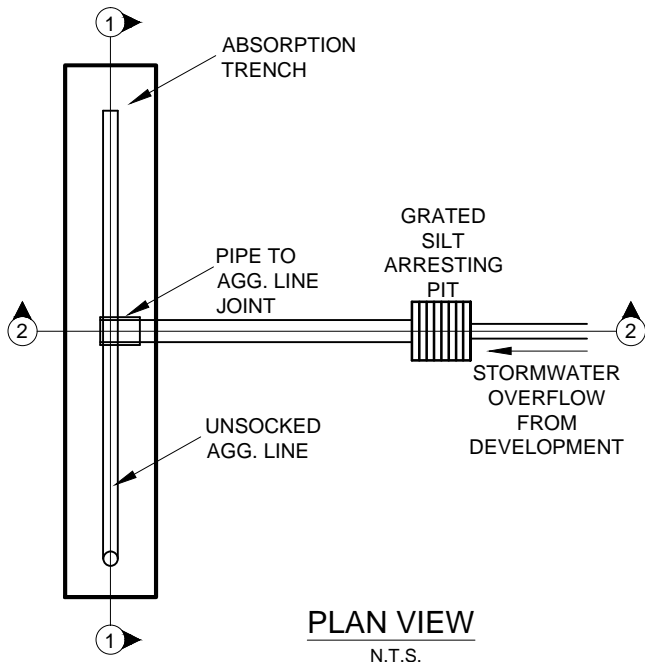

PLAN VIEW
N.T.S.

NOTES:

1. SILT ARRESTING PIT SIZE 400mm X 400mm (MINIMUM)
2. TRENCH LENGTH DETERMINED: 1m/25m² OF ROOF/HARDSTAND COLLECTED, OR PART THEREOF. (MINIMUM LENGTH 1m)
3. TRENCH 500mm WIDE & 500mm DEEP
4. 20-50mm AGGREGATE TO BE USED.
5. ONLY TO BE USED WHEN TOTAL AREA DISCHARGING TO TRENCH ≤75m².
6. TRENCH TO BE MINIMUM OF 3m FROM BUILDINGS AND PROPERTY BOUNDARIES, AND 1.5m FROM COUNCIL SEWER PIPES.

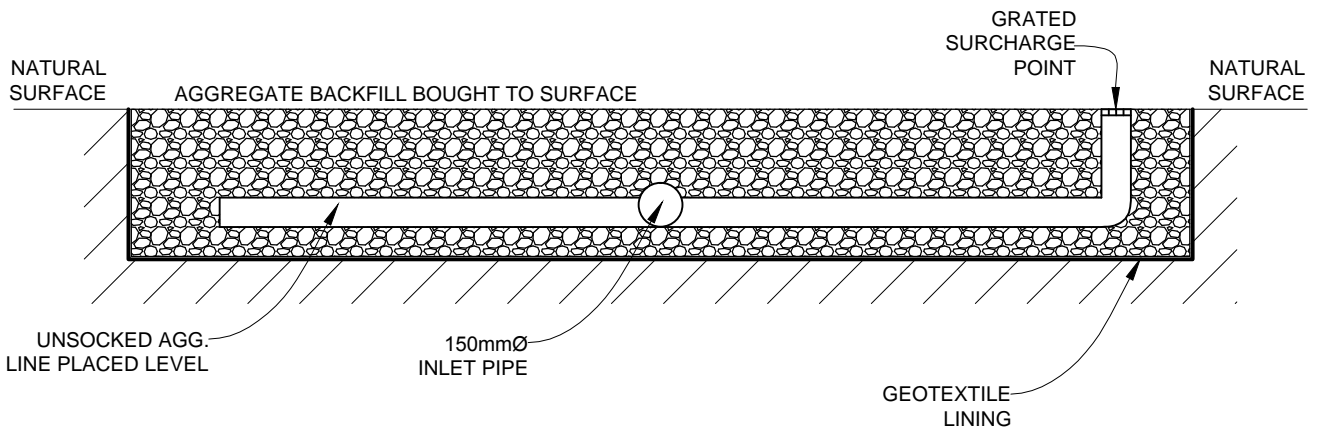

SECTION 1
N.T.S.

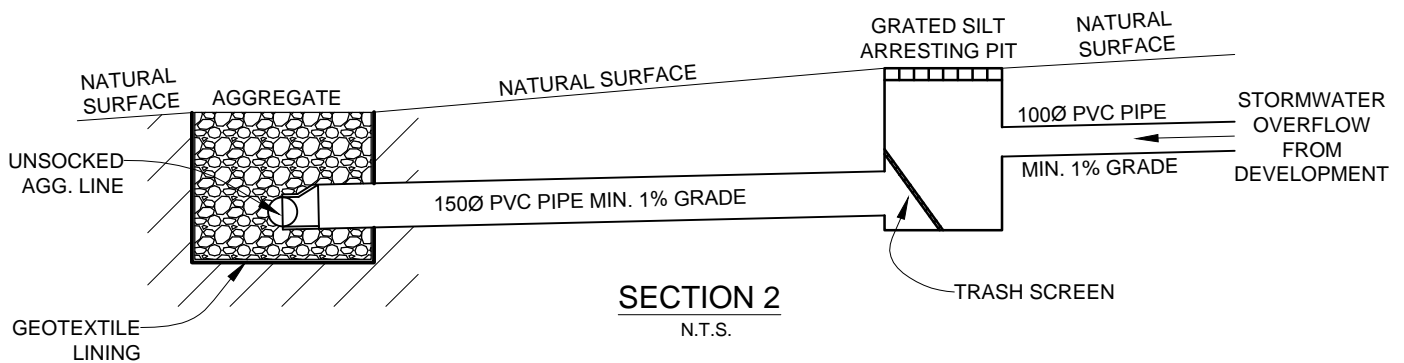

SECTION 2
N.T.S.



Approved On Behalf Of
EUROBODALLA SHIRE COUNCIL

Micheal McIlveen
Development Engineering
Coordinator
Date 15/05/2015



EUROBODALLA SHIRE COUNCIL

**ABSORPTION TRENCH LAYOUT
MINOR WORKS**

SD 4400	
Set	F
Amended	C-013-1

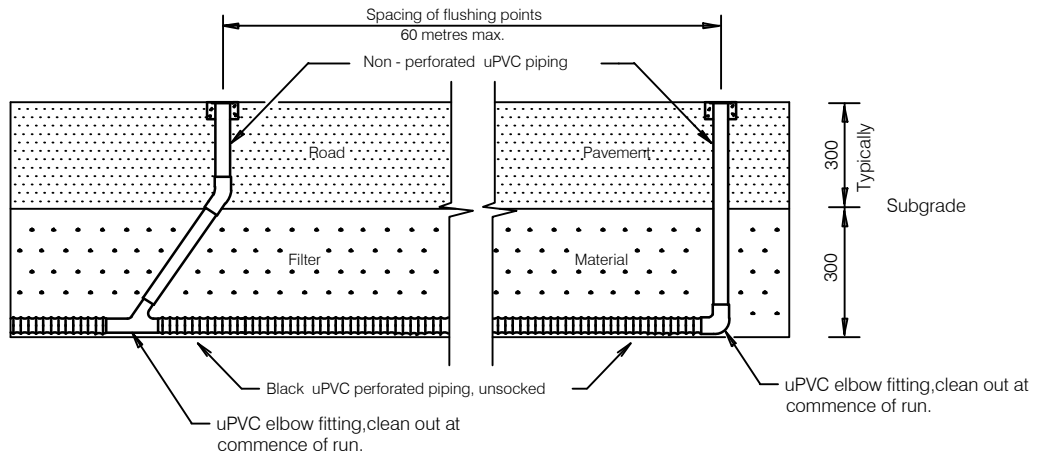

TYPICAL LONGITUDINAL SECTION

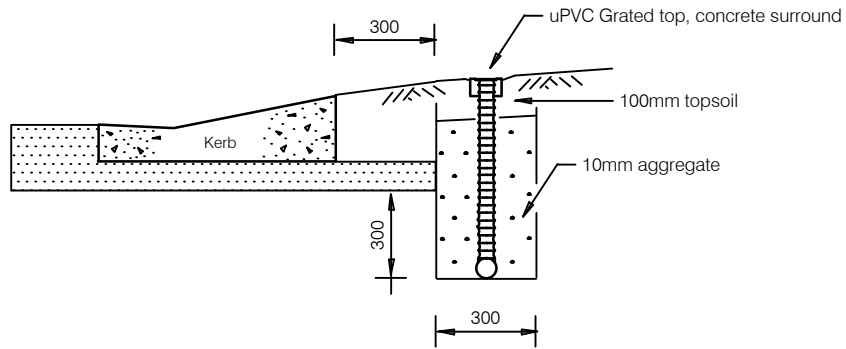

SECTION AT FLUSHING POINT

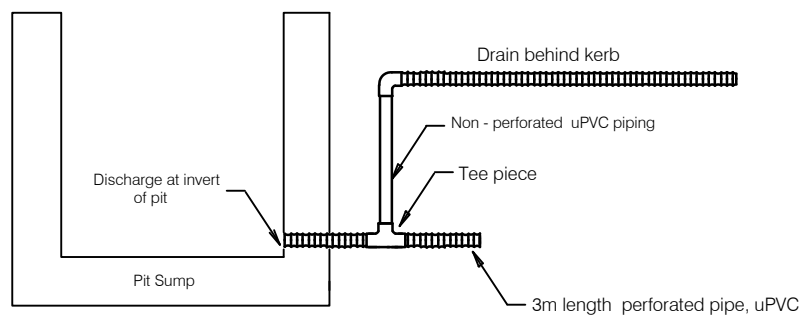

STORMWATER PIT CONNECTION



Approved On Behalf Of
EUROBODALLA SHIRE COUNCIL
Original Approved by
Richard Crompton for
Design & Construction Engineer
of Roads & recreation Services
Date 05 / 06 / 2007



EUROBODALLA SHIRE COUNCIL

Construction Specification
Subsoil Drains

Plan	4400-A
No.	005-b-1
Amend.	02/4/09

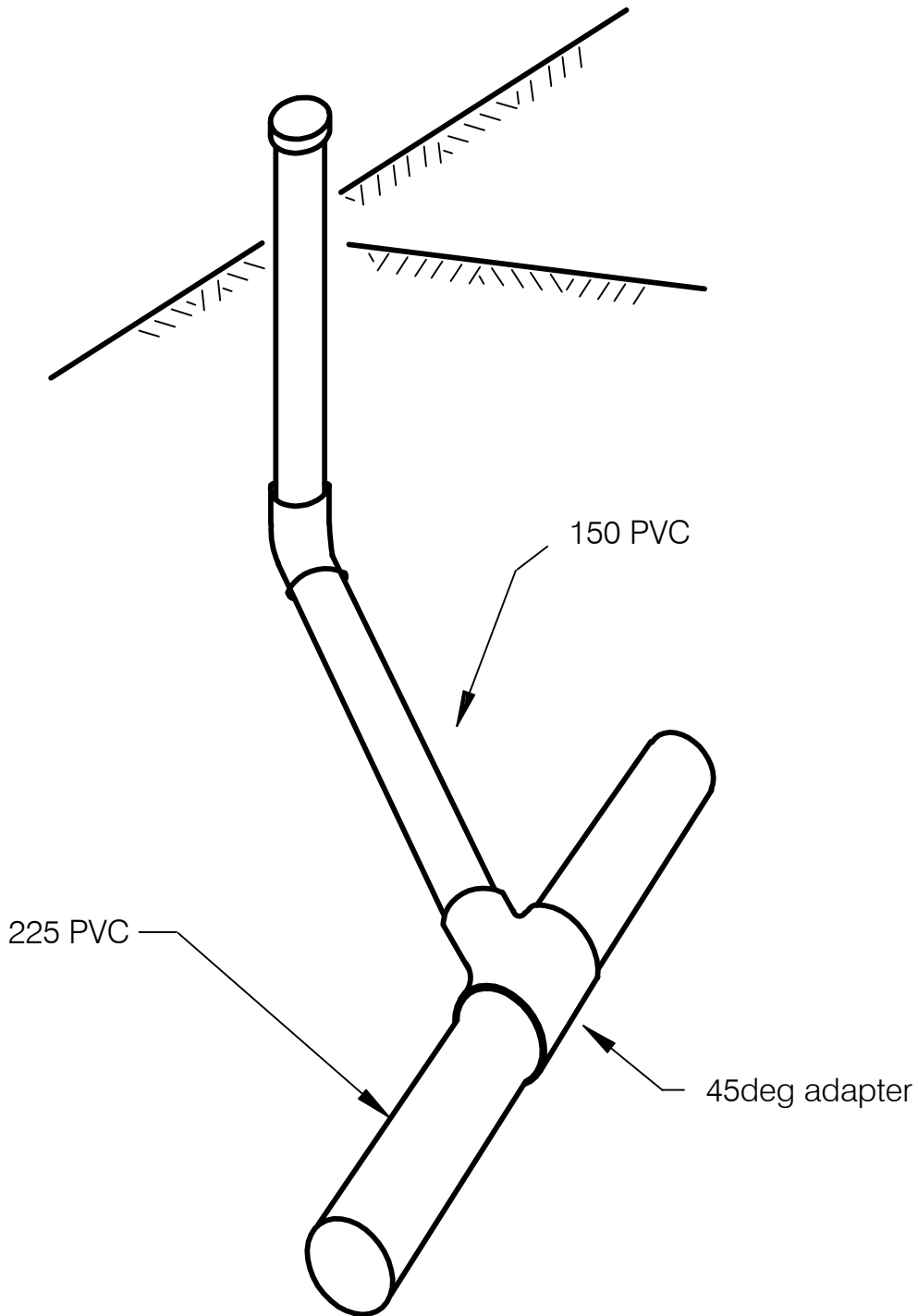

NOTE:

1. Install connection points 2m inside boundaries.
2. Riser pipe to protrude 500mm above surface, with capped top, marked SW
3. Riser pipe offsets are to be shown on Work as Executed Plans



Approved On Behalf Of
EUROBODALLA SHIRE COUNCIL
Original Approved by
Richard Crompton for
Design & Construction Engineer
of Roads & recreation Services
Date 29 / 06 / 2006



EUROBODALLA SHIRE COUNCIL
Construction Specification
Detail for House Stormwater
Connection Points

Plan	4400-A
No.	005-f-1
Amend.	02/04/09

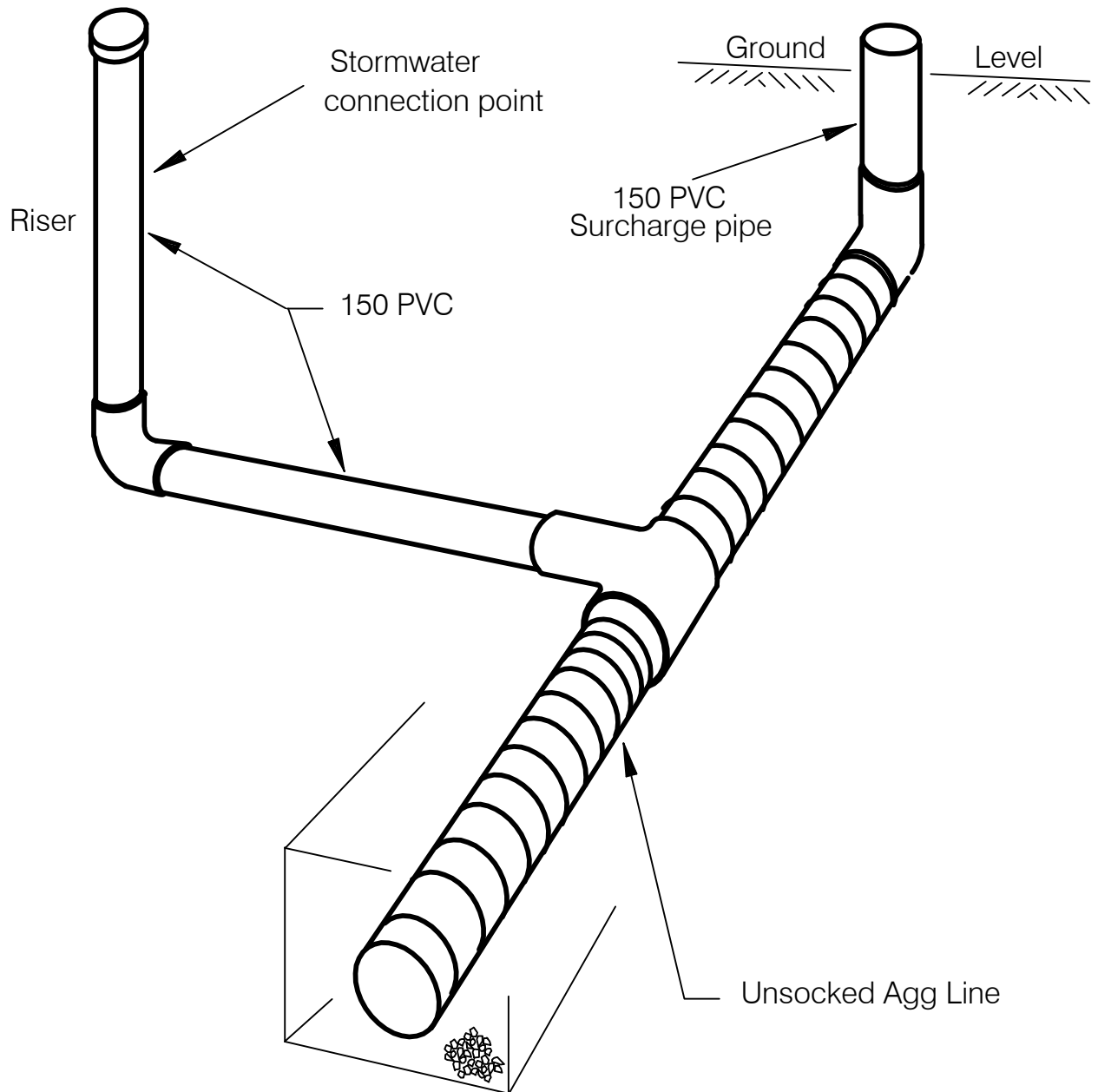

NOTE:

1. Install connection points 2m inside boundaries.
2. Riser pipe to protrude 500mm above surface, with capped top, marked SW
3. Riser pipe offsets are to be shown on Work as Executed Plans
4. Disposal unit to be placed in a trench, 0.5m depth by 3m length, backfilled with aggregate.
5. Ensure aggregate is brought to the surface, so water can percolate.



Approved On Behalf Of
EUROBODALLA SHIRE COUNCIL
Original Approved by
Richard Crompton for
Design & Construction Engineer
of Roads & recreation Services
Date 29 / 06 / 2006



EUROBODALLA SHIRE COUNCIL
Construction Specification
Absorption Trench Detail

Plan	4400-A
No.	005-g-2
Amend.	02/04/09

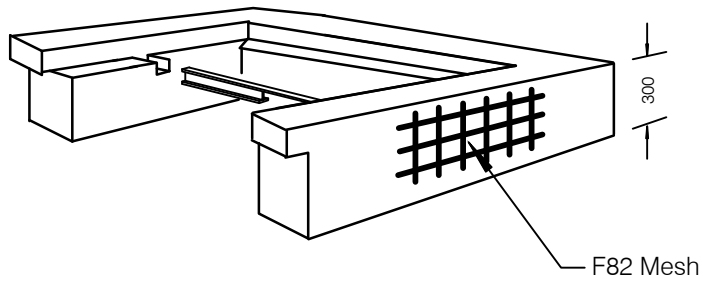

NOTE:
Gully Pit Surround
Concrete - 20MPa

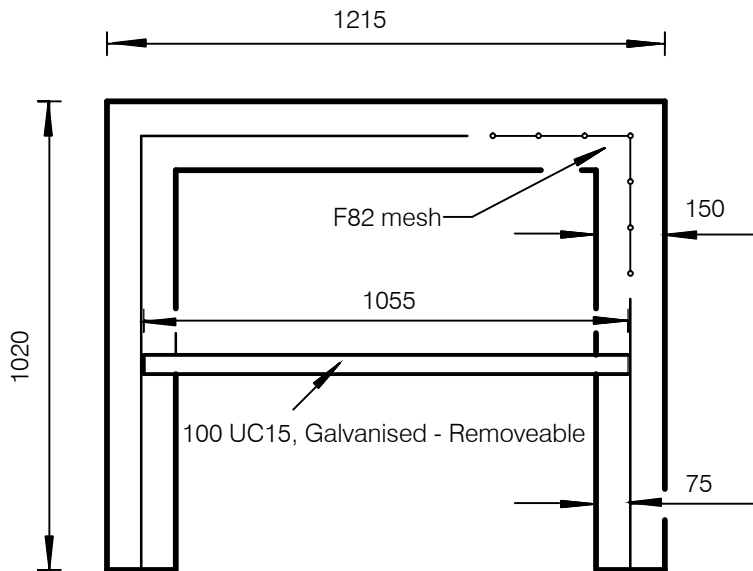

PLAN Gully Pit Surround

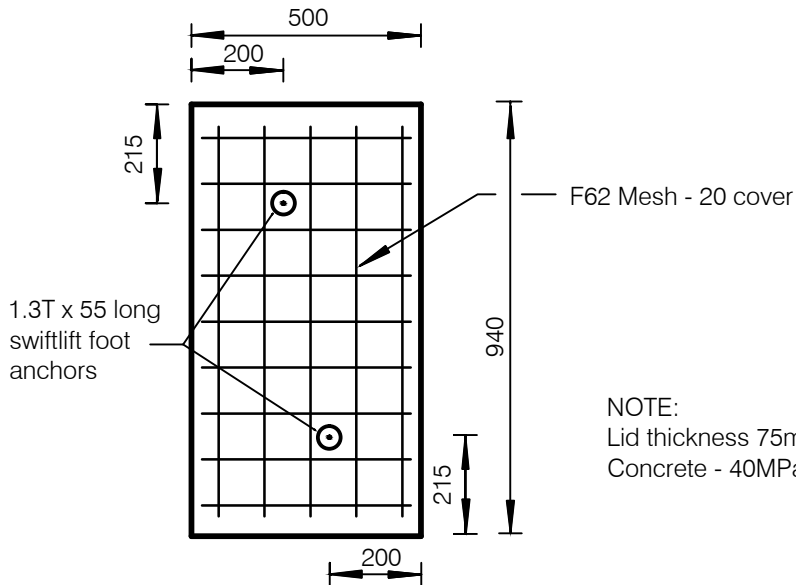

NOTE:
Lid thickness 75mm
Concrete - 40MPa

PLAN Concrete Pit Lids



Approved On Behalf Of
EUROBODALLA SHIRE COUNCIL
Original Approved by
Richard Crompton for
Design & Construction Engineer
of Roads & recreation Services
Date 01 / 12 / 2005



EUROBODALLA SHIRE COUNCIL

Construction Specification
Components for Councils Pits

Plan	4400-A
No.	005-h-1
Amend.	02/04/09

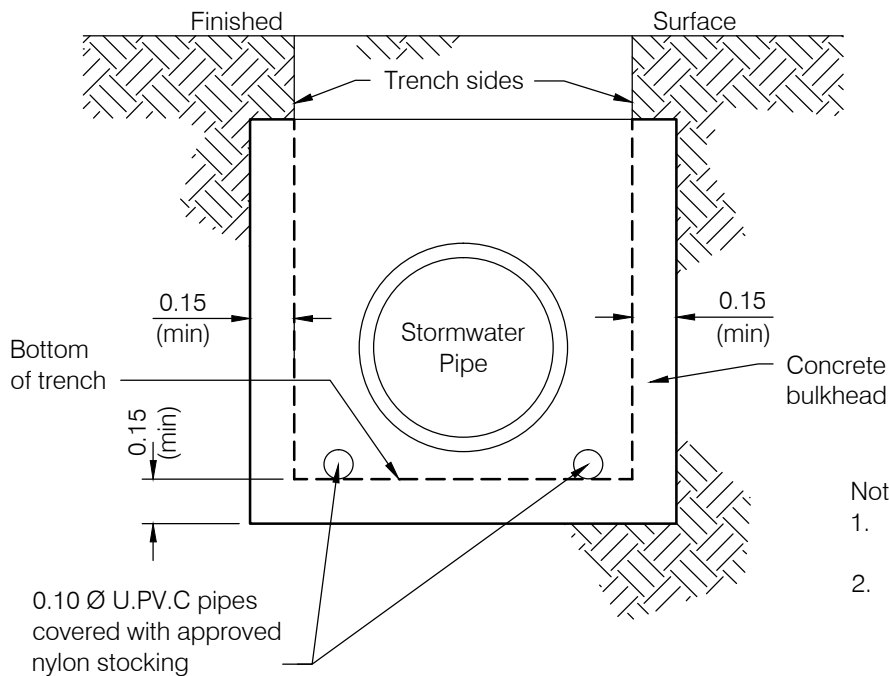
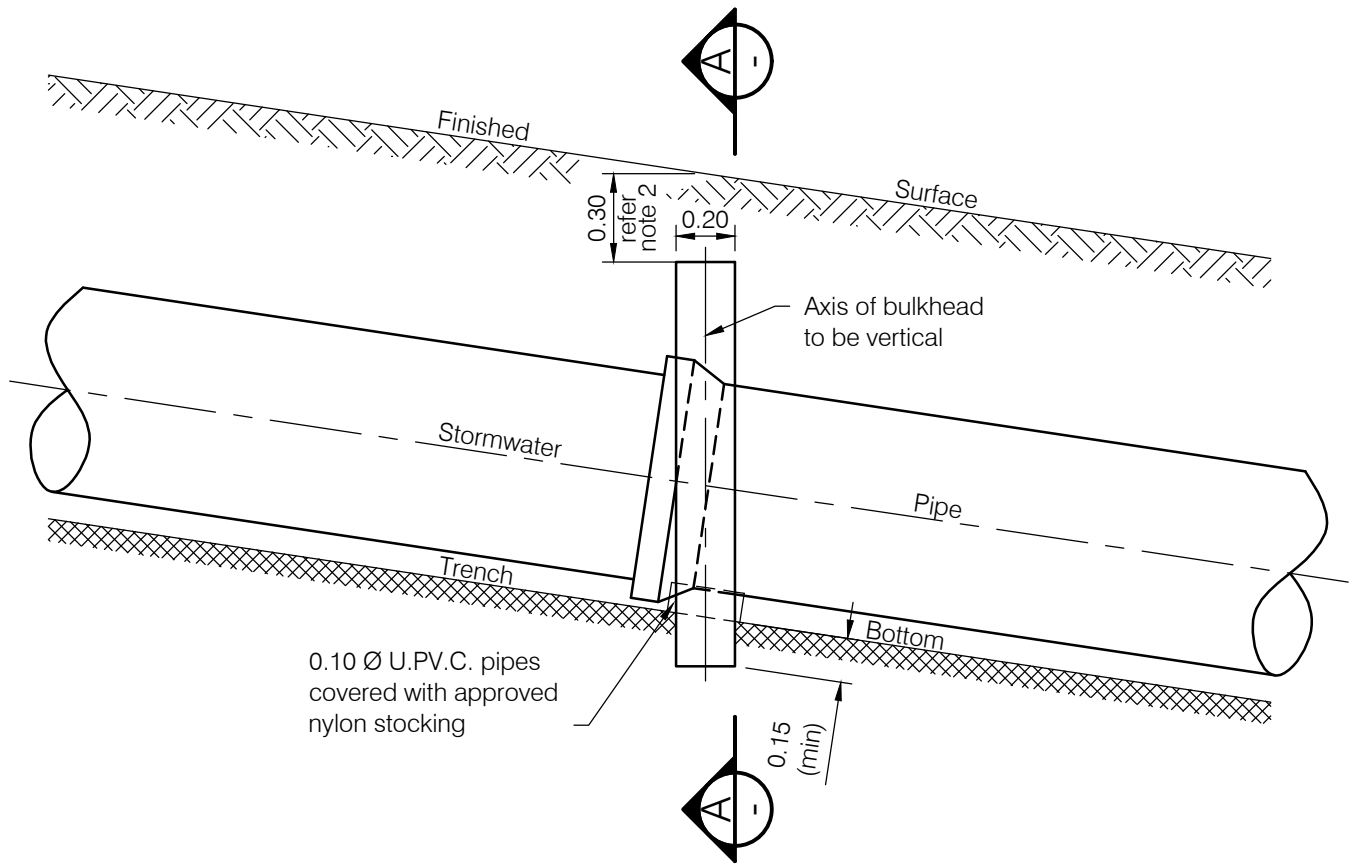

Section
NTS

A

Notes:

1. Compressive strength of concrete at 28 days to be 20MPa
2. Where the pipeline is under a road pavement, the top of bulkhead shall extend to subgrade unless otherwise directed by council's engineer.
3. Bulkheads required where grades are above 14% at max 8m c/c



Approved On Behalf Of
EUROBODALLA SHIRE COUNCIL
Original Approved by
Richard Crompton for
Design & Construction Engineer
of Roads & recreation Services
Date 14 / 10 / 2009



EUROBODALLA SHIRE COUNCIL

Construction Specification
Stormwater
Concrete Bulkheads

Plan	4400-A
No.	005-k
Amend.	

STORMWATER INLET PIT DETAIL

Connecting to Layback Kerb

- Sumps with a greater depth than 1.2m shall be fitted with galvanised step irons at 0.35m intervals. Refer Construction Specification 4400-A-005m
- All pits are to be provided with 3m of 100mm diameter sub soil drainage for all inlet trenches.
- Typical extended kerb inlets (EKI) is 1.8m maximum

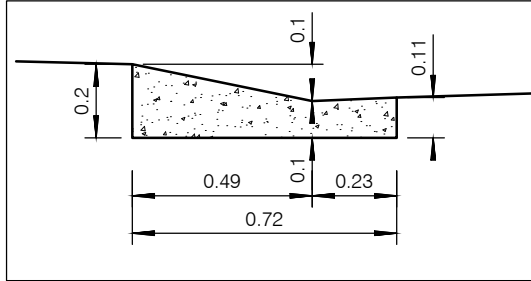

Section C-C

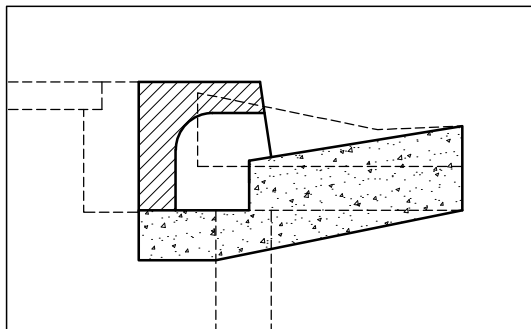

Section D-D

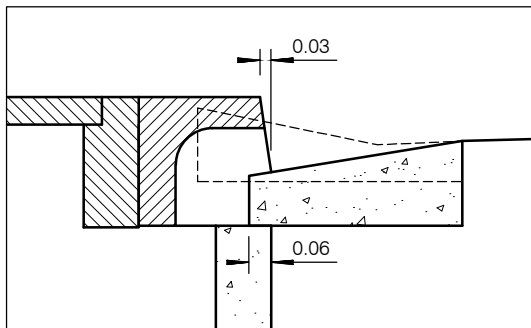

Lintel to kerb detail

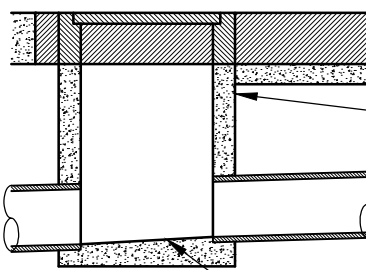

Section B-B

Minimum 0.05 drop through pit

Concrete pit - 20Mpa - 150mm th walls
0.9 x 1.2 internal dimension
Where pit depth greater than 1.2m :
Fit gal step irons at 0.35 intervals

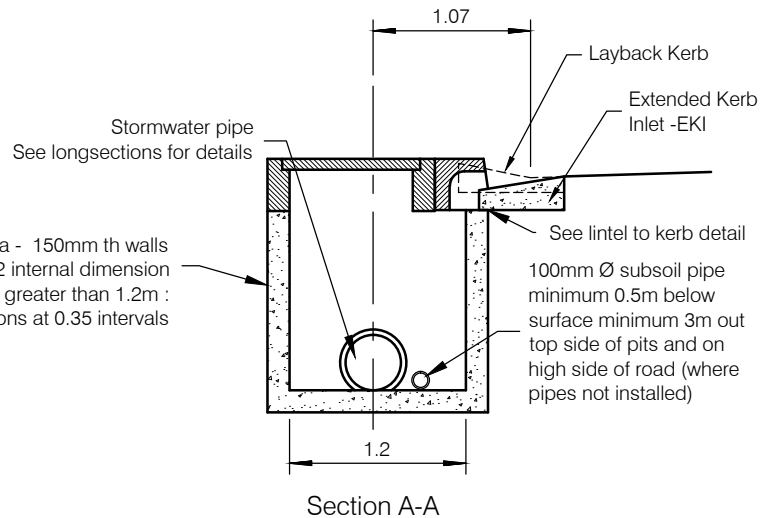

Section A-A

Prefabricated concrete lintel
Prefabricated concrete lid and surround
2 lids with lifting Holes

Setout Reference Point
See drainage longsections for
corresponding road CL offset

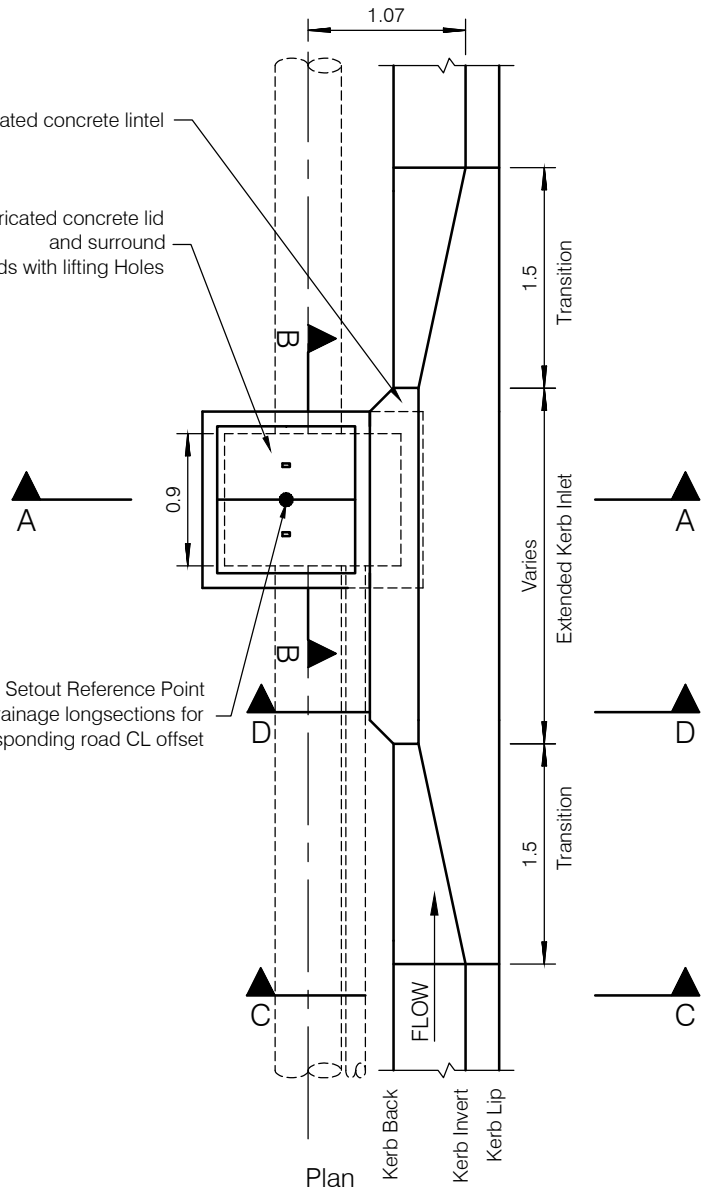

Plan

All dimensions in metres (unless otherwise shown)

Not to scale

Configuration shown is typical prefabricated units



Approved On Behalf Of
EUROBODALLA SHIRE COUNCIL
Original Approved by
Richard Crompton for
Design & Construction Engineer
of Roads & recreation Services
Date 01 / 12 / 2005



EUROBODALLA SHIRE COUNCIL

Construction Specification
Inlet Pit - Layback Kerb

Plan	4400-A
No.	005-j-3
Amend.	16/11/09

STORMWATER INLET PIT DETAIL

Connecting to Upright Kerb

- Sumps with a greater depth than 1.2m shall be fitted with galvanised step irons at 0.35m intervals. Refer Construction Specification 4400-A-005m
- All pits are to be provided with 3m of 100mm diameter sub soil drainage for all inlet trenches.
- Typical extended kerb inlets (EKI) is 1.8m maximum

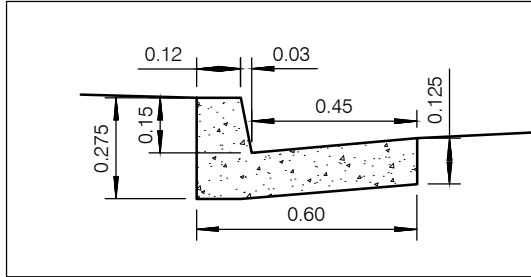

Section C-C

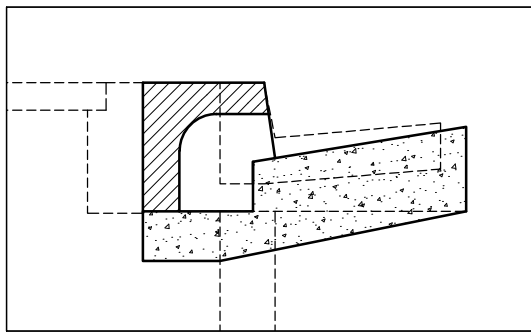

Section D-D

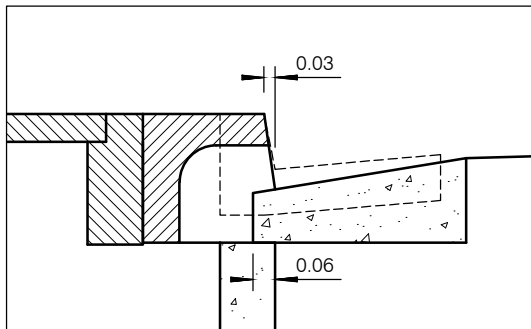

Lintel to kerb detail

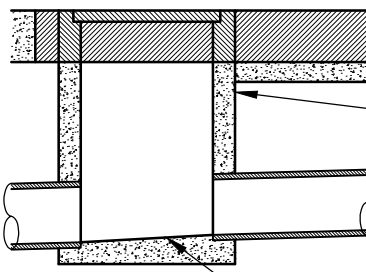

Section B-B

Minimum 0.05 drop through pit

Concrete pit - 20Mpa - 150mm th walls
0.9 x 1.2 internal dimension
Where pit depth greater than 1.2m :
Fit gal step irons at 0.35 intervals

Stormwater pipe
See longsections for details

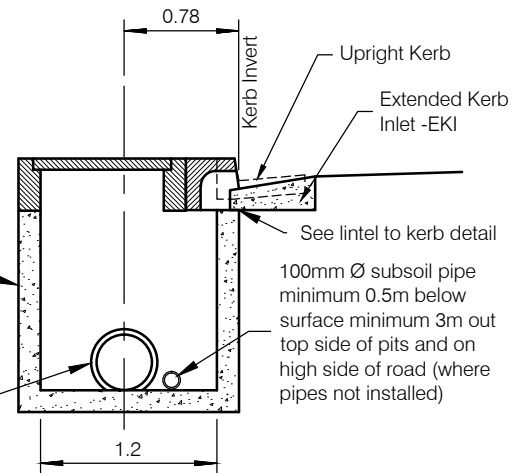

Section A-A

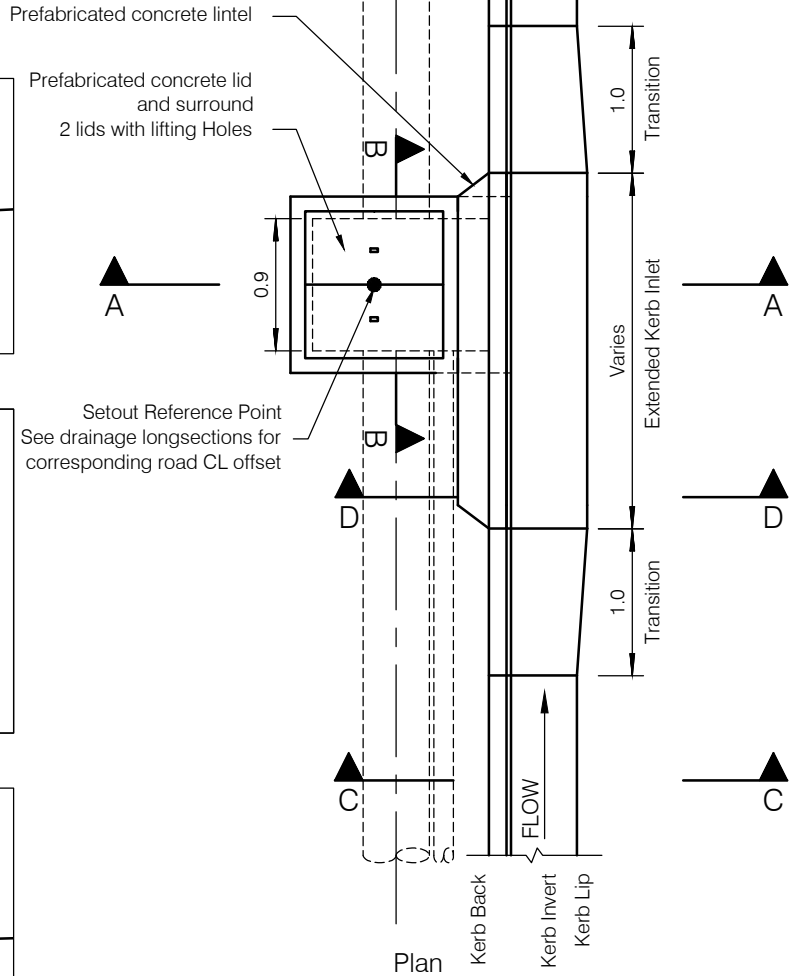

Plan

All dimensions in metres (unless otherwise shown)

Not to scale

Configuration shown is typical prefabricated units



Approved On Behalf Of
EUROBODALLA SHIRE COUNCIL
Original Approved by
Richard Crompton for
Design & Construction Engineer
of Roads & recreation Services
Date 17 / 11 / 2009



EUROBODALLA SHIRE COUNCIL

Construction Specification
Inlet Pit - Upright Kerb

Plan	4400-A
No.	005-1
Amend.	

Notes

1. All dimensions in millimeters
2. Position all Step Irons to water agency requirements
3. Step Irons to be hot dip galv.

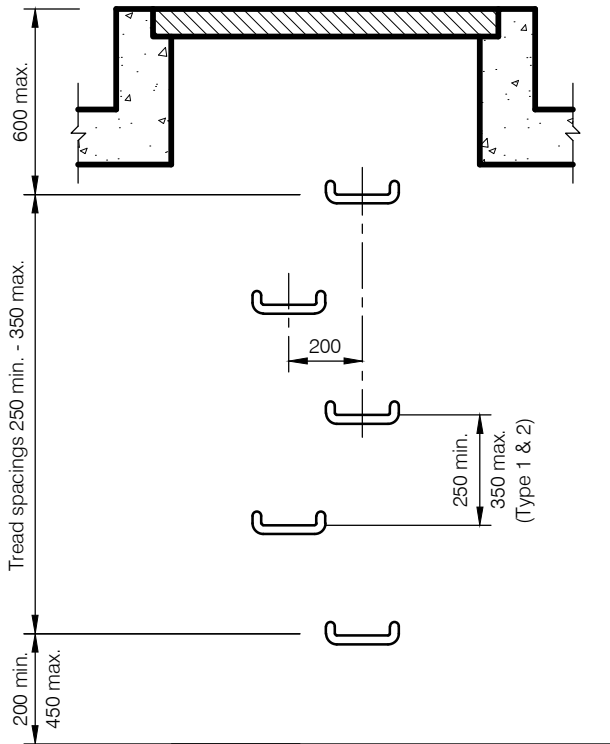

Elevation (Type 1 shown)

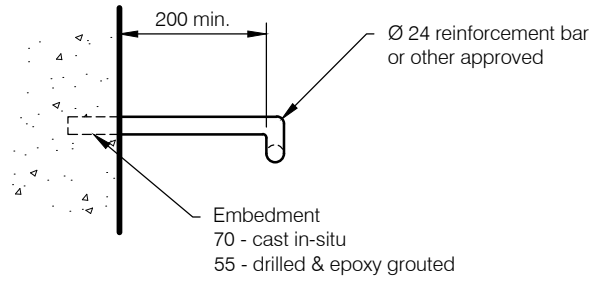

Rung - Section

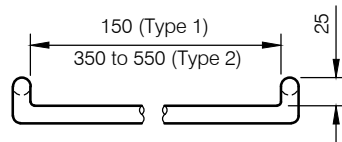

Rung - Front View

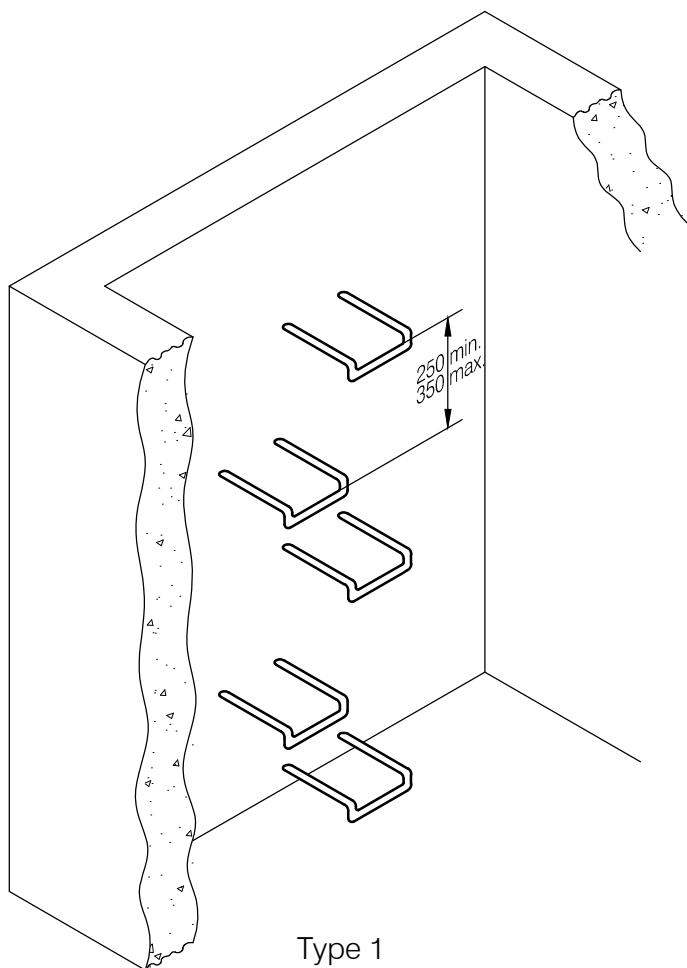

Type 1

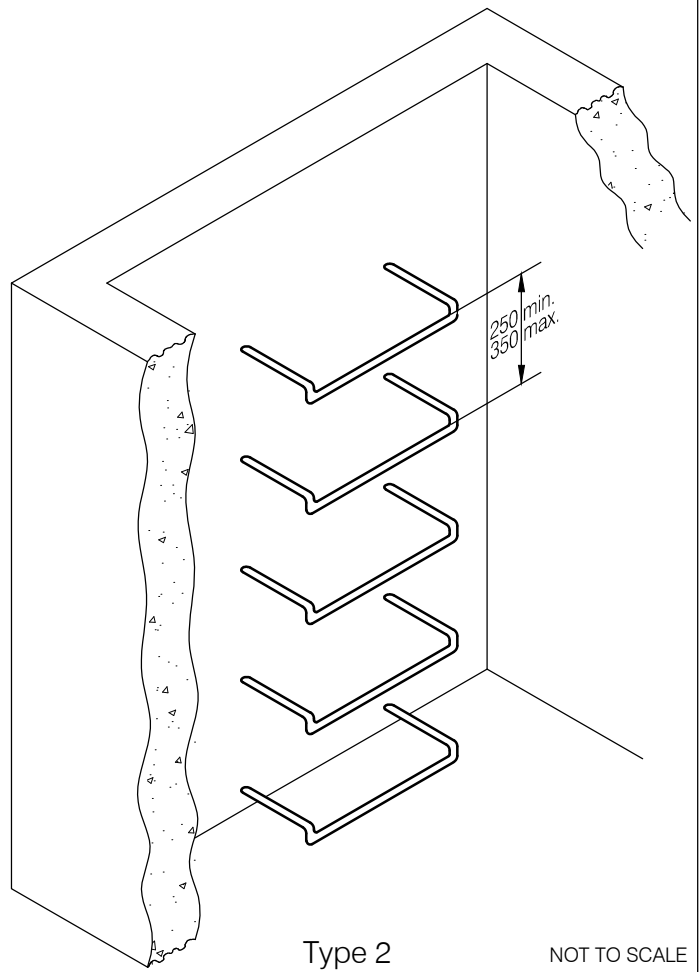

Type 2

NOT TO SCALE

 Design Section	Approved On Behalf Of EUROBODALLA SHIRE COUNCIL Original Approved by Richard Crompton for Design & Construction Engineer of Roads & recreation Services Date 14 / 01 / 2010	 EUROBODALLA SHIRE COUNCIL <i>Good Government. better living</i>	EUROBODALLA SHIRE COUNCIL Construction Specification Step Irons	Plan 4400-A No. 005-m Amend.
--	--	--	---	------------------------------------

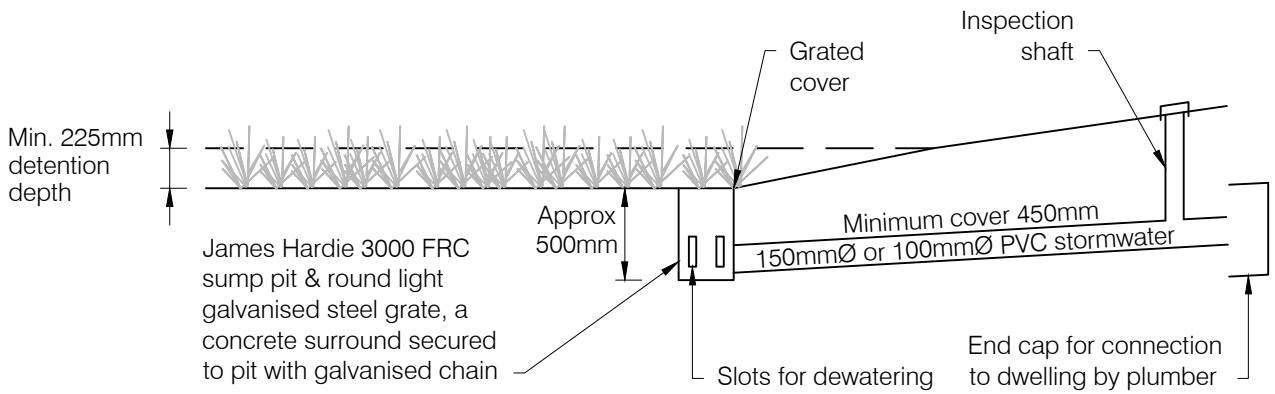

Surcharge Pit Detail

Not to scale



Approved On Behalf Of
EUROBODALLA SHIRE COUNCIL
Original Approved by
Richard Crompton for
Design & Construction Engineer
of Roads & recreation Services
Date 22 / 04 / 2010



EUROBODALLA SHIRE COUNCIL

Construction Specification
Rain Garden Detail - Barlings Beach

Plan	4400-A
No.	005-n
Amend.	

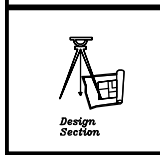
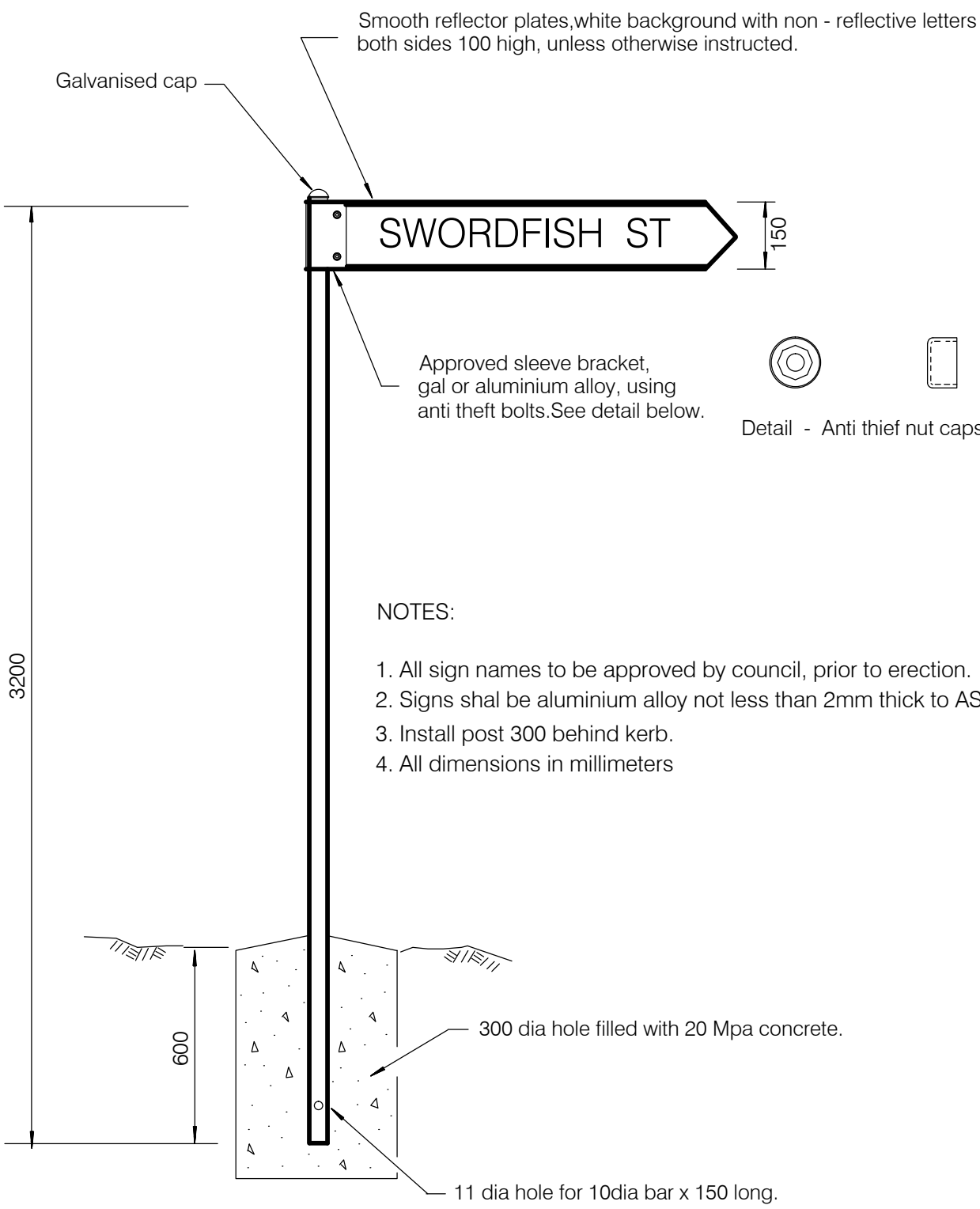

Approved On Behalf Of
EUROBODALLA SHIRE COUNCIL
 Original Approved by
 Richard Crompton for
 Design & Construction Engineer
 of Roads & recreation Services
 Date 09 / 05 / 2005



EUROBODALLA SHIRE COUNCIL
 Construction Specification
 Sign Post Detail

Plan	4400-A
No.	004-a-1
Amend.	17/3/09

Infrastructure Design Standard

19 Appendix D – Version control

Version	Amendment/s	Authorised	Date

Infrastructure Design Standard

20 Appendix E – Design checklists and forms

Infrastructure Design Standard

20.1 Design Engineer's Checklist #1 Construction Certificate

Design Engineer's Checklist #1 Construction Certificate			
To be submitted with request for DETAILED design approval			
Development:		Stage:	
Development Consent number:		Consultants reference:	
Consultant's representative:		No. of plans in set	
ITEM	Y/N/NA/ COMMENT	INITIAL	
General design requirements			
The detailed design is in accordance with the development consent conditions and the approved plan, and physical design features incorporated on construction plans.			
Plan of subdivision has been certified at the time of this submission?			
The detailed design is in accordance with the plan for certification?			
Easement locations and widths are in accordance with certified plan?			
The detailed design is in accordance with Council's IDS.			
Environmental protection during development construction has been considered and requirements are documented (eg erosion protection, silt migration etc.)			
Revegetation requirements have been considered and are documented.			
Protection of water bodies and waterways has been considered and requirements are documented.			
List approvals already received from other service authorities.			
General plan requirements			
Drawing list is presented.			
Council nominated drawings numbers are shown.			
Locality plan is presented.			
North arrow is shown on all layout plans and detailed plans (should be shown up or to left).			
All plans have correct scales shown.			
All plans have comprehensive legends.			
Do plans include standard notes? Are they applicable and clear?			
Plans clearly show allotment layout, with allotments numbered and dimensioned, and reserves and easements are clearly identified.			
Limit of works is shown on all layout plans in set.			
Dams, wells, depressions and watercourses are identified and fill requirements identified.			
Existing fill areas are shown.			
Existing features and structures are shown.			
Existing service locations and poles are shown.			
Existing trees are shown. Does design attempt to retain trees?			
Existing native vegetation is shown and suitably specified? Does design attempt to retain significant native vegetation?			

Infrastructure Design Standard

ITEM	Y/N/NA/ COMMENT	INITIAL
Road layout plans		
Datum shown to AHD.		
Scales are in accordance with the IDS requirements.		
PSM's and TBM's marked on plans. SSM to be moved.		
Proposed service locations and offsets are tabulated.		
All required service conduit locations are indicated on the plans.		
Footpaths minimum width of 1.5 m, and located at correct offset.		
Shared paths minimum width of 2.5 m, and location clearly shown.		
Kerb crossings are at appropriate locations and fully documented.		
Vehicle crossings are shown on plans.		
All vehicle crossings cater for standard car.		
Are any crossings located over easements?		
All turning movements have been checked in accordance with IDS, and intersections designed accordingly.		
Street names are shown on plans and have Council approval.		
Road widths between inverts of kerbs are nominated.		
Kerb profiles are nominated.		
Street name signage, linemarking, and traffic control plans		
Locations and type of all new signage is shown on plans, and comply with Australian Standards.		
Any existing signage to be removed or relocated is shown on plans.		
Locations and type of all linemarking is shown on plans, and comply with Australian Standards.		
Any existing linemarking to be removed is shown on plans.		
Traffic calming devices are designed and documented in accordance with Austroads and any RMS supplement to those guidelines and the IDS, and as per approved plans.		
Limit of works of roads include temporary turning area if required. "No Road" signage or hazard markers to be provided unless otherwise agreed with Council.		
Road longitudinal sections		
Road names are shown on longitudinal sections.		
Scales are in accordance with the IDS requirements.		
Datum RL to AHD shown.		
Natural surface profile and levels shown at crown.		
Design surface profile and levels shown at crown.		
Levels have been checked by design engineer and (i) comply with the IDS, and (ii) match into existing.		
Depth of cut/fill to crown is shown.		
Design surface profile and levels shown at left and right back of kerb (including high and low points).		

Infrastructure Design Standard

ITEM	Y/N/NA/ COMMENT	INITIAL
Road longitudinal sections continued		
Gradings as + or – percent to two (2) decimal places shown in direction of chainages.		
Grades have been checked by design engineer and (i) comply with the IDS, and (ii) match into existing. Min. grade..... ; % Max. grade.....; % Match existing		
All vertical curve lengths and I.P values are shown.		
Vertical curve levels are shown at maximum intervals of 10m		
Minimum kerb grades are achieved.		
Levels and grades given on long sections have been checked by the design engineer.		
Check levels and grades match into existing abutting roadworks.		
Minimum length of vertical curve for >1% grade change to be 15 m (except on kerb returns).		
External road grading for future stages to extend a min. of 100m		
Vertical curves and longitudinal grades provide satisfactory sight distances for standard roads, particularly at intersections.		
Coordination of vertical and horizontal curves has desirable design outcome?		
Is vertical curve entirely within or outside horizontal curve?		
Road cross-sections		
Design engineer has checked that cross-sections agree with longitudinal sections.		
Datum is shown on every cross-section.		
Scales comply with IDS.		
Road names and chainage references are shown.		
Natural and design levels are given at: <ul style="list-style-type: none"> • Back of kerb • Lip of kerb • Crown • Property lines • Front of footpath • Table drain inverts (where applicable) • Top and toe of batters (where applicable). 		
All crossfalls are in accordance with the IDS: - pavements - nature strips - footpaths – batters.		
Typical cross-sections and traffic/road details		
Typical cross-sections are presented in accordance with Appendix B –Information shown on plans and requirements of this IDS		
Typical cross-sections note road name and chainage references, if applicable		
Profile and geometry of design surface grades are shown as % or 1 in X and comply with IDS requirements		
Details of road pavement construction, including materials, compaction and type of seal are shown.		

Infrastructure Design Standard

ITEM	Y/N/NA/ COMMENT	INITIAL
Typical cross-sections and traffic/road details continued		
Details of footpath construction, including materials, compaction and seal are shown, or standard drawing noted.		
Typical alignment of services, subsoil drainage and landscaping are shown.		
Kerb and channel types are nominated.		
Kerb and channel construction is detailed or standard drawings noted.		
Intersection, cul- de- sac and curve details		
Road names are shown.		
Road chainages are shown.		
Intersection details are shown at correct scales in accordance with IDS.		
At least four kerb levels are given on every kerb radial.		
Tangent point levels and chainages align with longitudinal and cross sections.		
Set-out details are shown including angle, radii and tangent points.		
Design surface contours are shown to AHD at 50 mm maximum intervals.		
Back of kerb levels are shown to AHD.		
Footpath levels are shown.		
Location of low points are shown.		
Services (inc drainage) are shown in detail.		
Landscaping is shown in detail.		
Footpath and kerb crossings are shown in detail.		
Drainage layout plans		
Design engineer has checked that drainage design is in accordance with AR & R		
Datum shown to AHD		
Scales are in accordance with IDS requirements		
PSM's and TBM's marked on plans to AHD		
Finished surface levels are shown where the natural surface is altered.		
Plans clearly show allotment layout, with allotments numbered and reserves and easements are clearly identified.		
1:100 year flood levels shown.		
Road names are shown.		
Plans shown layout of proposed drainage systems with offset from property boundaries.		
Pipe materials and diameters are shown.		
Design engineer has checked that drainage design in accordance with AR&R.		
Datum shown to AHD.		
Overland flow path is shown and outfall has Council approval.		

Infrastructure Design Standard

ITEM	Y/N/NA/ COMMENT	INITIAL
Drainage layout plans continued		
Kerb and channel and footpath is depressed where overland flow path leaves road pavement.		
Subsurface drains, house drains and property inlets are shown.		
Pits are at appropriate locations (eg away from kerb returns, vehicle crossings, kerb crossings etc.).		
Pit spacing is 80m maximum.		
Pit capacity checked by design engineer.		
Double SEP"s at confined low points only.		
Change in angle is not greater than 90°..		
Pits/headwalls are numbered.		
Set-out point of pits is clearly shown on legend.		
Footpath spoon drains have adequate outfall.		
Back of kerb drainage (eg roundabout kerbs) has adequate outfall.		
All existing fences, buildings, trees etc shown in path of overland flows.		
All proposed fences, buildings, trees etc shown in path of overland flows.		
Existing or proposed open earth drains, dams, watercourses, boreholes, sink holes, wells and springs within the area are shown.		
Extent of required erosion protection is shown at headwalls and other structures.		
Drop structures are shown.		
All properties have identified drainage discharge points (to underground drainage systems for industrial and commercial developments, and residential wherever possible).		
Drainage longitudinal sections		
Longitudinal sections are prepared for all legs of drainage and for open drains and nominated overland flow paths		
Scales are in accordance with the IDS		
Comprehensive legend to be shown		
Datum RL to AHD shown		
Drainage line numbers names are shown on longitudinal sections.		
Drainage line chainages are shown on longitudinal sections.		
Lengths of drainage sections do not exceed 80m		
Pipe diameter, class and grade is shown for all legs of drainage.		
Pipe classes have been determined with consideration to construction loads, not just final cover. Cross-check compaction requirements in documentation.		
Pipes with steep grades are documented to include anchor blocks.		
Pit number and pit type is shown.		
Pit type matches capacity requirements.		
Any special pits are fully documented.		
Internal pit dimensions are shown		
Pit inlet and outlet levels are shown		

Infrastructure Design Standard

ITEM	Y/N/NA/ COMMENT	INITIAL
Drainage longitudinal sections continued		
Depths of pits to invert levels are shown.		
Finished top of pit levels and finished surface level adjacent to pits are shown.		
Pit lid type and class are shown.		
Origin/destination pits for inlet and outlets.		
Junction line numbers are noted.		
Design pipes are plotted on longitudinal section.		
Hydraulic grade line is plotted and levels given.		
Check that maximum depth in roadway is 500mm (ie., at invert).		
Check that depth x flow factor is acceptable.		
Required 150mm freeboard to kerb invert is achieved for minor storms.		
Energy losses in drainage system are accounted for.		
Crosses with other services are plotted and clearances nominated (street names should be referred to identify crossings).		
Design flows are shown (litres/second).		
Design velocities are shown (metres/second) and comply with Manual.		
FCR backfill is specified under road pavements, footpaths, crossovers and building lines.		
The location and type of special backfill requirements are noted (eg to prevent piping of backfill material).		
Design is in accordance with AS 3725 and its commentary.		
Open drains		
Shape of drain is suitable for maintenance.		
Drain is accessible from both sides and all weather tracks provided		
Depth of floodways is shown on cross-sections and less than 1.5m		
Scour velocities and siltation were both checked in determining longitudinal grades.		
Grade control / drop structures are fully documented.		
Low flow pipe has been provided in accordance with the Specification.		
Outfall structures are provided and energy dissipators provided if needed.		
500mm minimum freeboard is achieved.		
Detail plans		
Non-standard drainage structures are fully detailed for construction - headwalls - drop structures - erosion protection at outlet structures - erosion protection for batters where needed.		
Non-standard pits are fully documented including reinforcement and pit lid details.		
Structural details of all retaining walls are shown, as well as details of natural surface levels and design surface levels, foundation requirements, drainage requirements, and type of finish.		

Infrastructure Design Standard

ITEM	Y/N/NA/ COMMENT	INITIAL
Detail plans continued		
Structural details of all retaining walls are shown, as well as details of natural surface levels and design surface levels, foundation requirements, drainage requirements, and type of finish.		
Drainage pump stations fully documented.		
Layout and details of power installation documented.		
Details of any estate entrance structures, including structural details, location details and method of finish.		
Traffic calming devices are fully detailed to ensure construction is in accordance with design requirements (eg splitter islands, chicanes, speed humps, roundabout construction).		
Lot filling plans		
Natural surface contours are shown with 100 mm max. intervals.		
Design surface contours are shown with 100 mm max. intervals.		
Finished surface levels are shown and all allotments have minimum 1:100 grade toward low point.		
Proposed fill in excess of 300mm is clearly denoted on plans.		
Material and compaction requirements are fully documented to relevant Australian Standard in either plans or specification.		
Extent of lot filling, top and toe of batters and retaining walls all noted.		
Drainage detention and treatment		
Computations are provided to verify the volume of the basin.		
Erosion protection is fully documented.		
Inlet structures are fully documented.		
Overflow is identified and appropriate.		
Freeboard is achieved.		
Wetland plantings have alternative source of water for establishing plants and for periodic dry spells.		
Master services plans		
Plans show numbered allotments, road reserves and road carriageways.		
Street light types are nominated for approval.		
ALL underground service alignments are shown, including non-essential services such as raw water and irrigation lines.		
ALL major aboveground features are shown such as street lights, power supply pillars, fencing, landscaping etc.		
Landscaping plans		
Detailed irrigation layout plans is provided showing valves, controllers, pipe material and sizes, alignments, nozzle details, and backflow devices.		
Planting schedule is included, including size of plants.		
Location of major plantings is clearly shown.		

Infrastructure Design Standard

ITEM	Y/N/NA/ COMMENT	INITIAL
Landscaping plans continued		
Planting requirements are documented including dimension of hole, root barrier, backfill, mulch, stakes, tree grates, tree guards and stakes details		
Details of any trees or vegetation to be removed.		
Street furniture and signage is detailed including type, colour, location and installation.		
Lighting details		
Supply and installation details of playground equipment		
Path, bollard and fencing construction details		
Location of any services within landscaped areas		
Open water bodies to cross reference to other detention basin or drainage plans.		
Associated documents		
If required, a TMAR was prepared and accompanies this submission.		
If required, a TIAR was prepared and accompanies this submission.		
If required, a Road Safety Audit Report was prepared and accompanies this submission.		
Note any deviations between the proposed design and the recommendations within the Road Safety Audit report.		
Hydrological calculations are provided for whole of catchment and partial areas if relevant, and 100yr ARI design flows calculated at critical points. (Method nominated and assumptions clearly stated ARI's in accordance with Manual)		
Hydraulic calculations are provided for above and underground drainage, for major and minor storm events. (Method nominated and assumptions clearly stated. Roughness coefficients nominated).		
Copy of geotechnical reports are provided with submission.		
Road pavement design is provided with submission.		
Quality assurance sections are included in specification.		
Risk assessment report is provided for drainage detention and treatment infrastructure.		

The plans, specifications and associated documents provided with this submission for detailed design approval have been prepared in accordance with the relevant Sections of the Council's IDS. All of the above checklist items have been initialled as correct and complete, or marked N/A (not applicable) as appropriate.

Signed _____

Dated: _____

Infrastructure Design Standard

End of document